

Model No. KR-150N5DM
 MAX INLET: 5000 PSI
 REGULATED OUTLET: 300-3000 PSI
 SPECIFIED FLOW: 150 GPM
 Cv Inlet: 14.9
 Cv Vent: 4.1
 VENT PORT: (2) 1" NPT
 INLET PORTS (2): 1" NPT
 OUTLET PORT: 1 1/2" NPT
 OPERATOR: MANUAL OPERATOR

- MATERIALS:**
- BODY: STAINLESS STEEL
 - FLANGES & OPERATORS: CARBON STEEL
 - INTERNAL: STAINLESS STEEL
 - O-RINGS: BUNA (NITRILE)
 - BACKUPS: TEFLON
 - BOLTS : STEEL (A574)

TEMPERATURE RATING: -30°F TO 180°F
 WEIGHT: 71 LBS

PROPRIETARY AND CONFIDENTIAL
 THE INFORMATION CONTAINED IN THIS DRAWING IS THE SOLE PROPERTY OF PacSeal Hydraulics. ANY REPRODUCTION IN PART OR AS A WHOLE WITHOUT THE WRITTEN PERMISSION OF PacSeal Hydraulics IS PROHIBITED.

	NAME	DATE
DRAWN	FS	6/12
CHECKED	LB	6/12
ENG APPR.	JB	6/12

COMMENTS:



PacSeal Hydraulics

TITLE:
KR-150N5DM - Manual

SIZE A	DWG. NO. 40-1698	REV 2
SCALE: 1:6	WEIGHT: 71	SHEET 1 OF 2

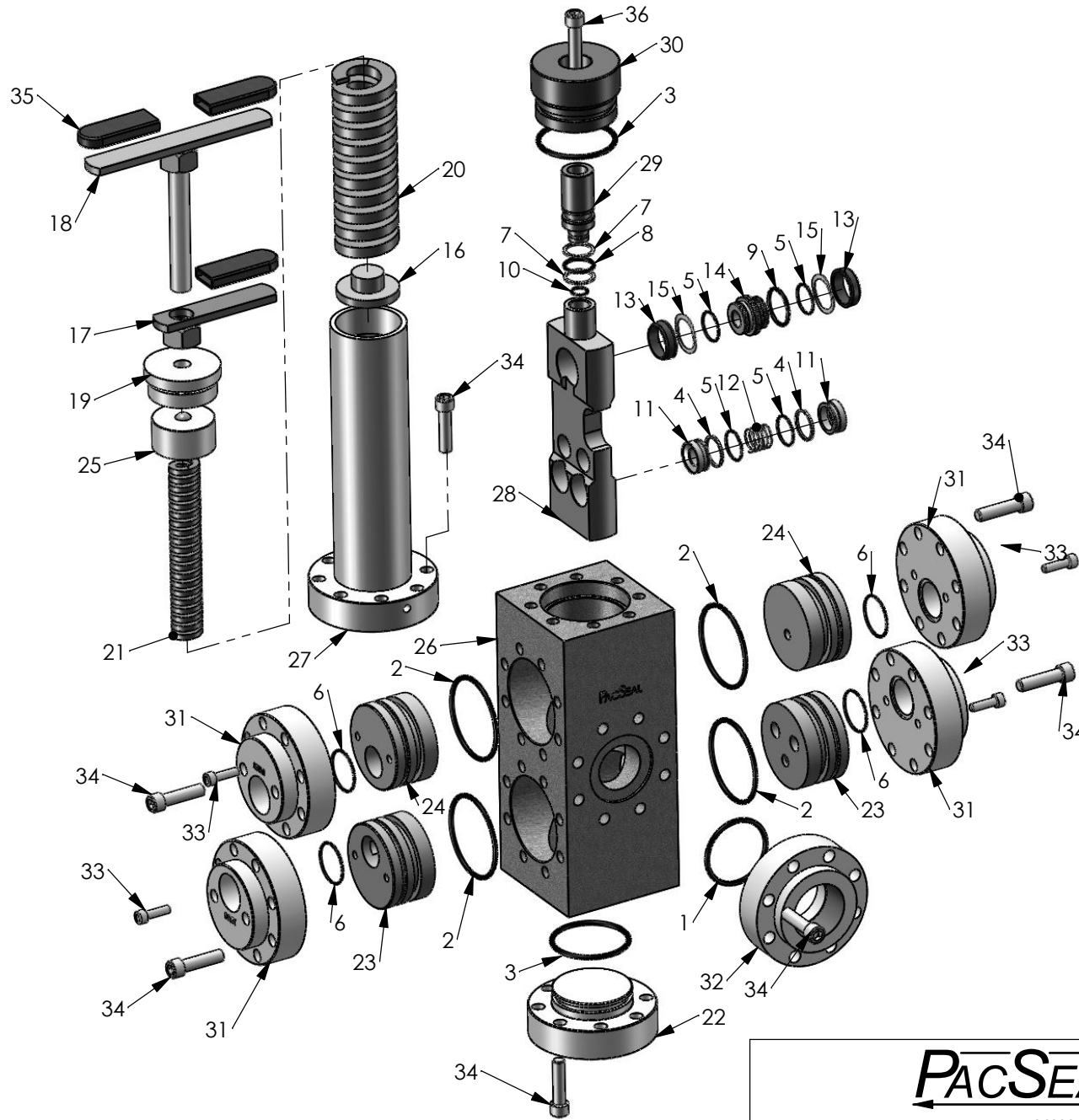

ITEM NO.	PART NUMBER	DESCRIPTION	QTY.
1	23-1126	O-Ring	1
2	23-1263	O-Ring	4
3	23-1319	O-Ring	2
4	23-1322	Backup Ring	4
5	23-1323	O-Ring	6
6	23-1325	O-Ring	4
7	23-1331	Backup Ring	2
8	23-1332	O-Ring	1
9	23-1334	O-Ring	1
10	23-1343	O-Ring	1
11	40-0014	Seal Ring, Supply	4
12	40-0110	Spring	1
13	40-0113	Seal Ring- Vent, KR-100	2
14	40-0114	Valve, Cage	1
15	40-0115	Wave Spring	2
16	40-0134	Spring Plate	1
17	40-0135	Lock Handle	1
18	40-0136	Adjusting Handle	1
19	40-0140	Plug, Adjustment Head	1
20	40-0143	Spring, Outer	1
21	40-0144	Spring, Inner	1
22	40-0197	Flange, Lower	1
23	40-0285	Flow Plate, Supply	2
24	40-0286	Flow Plate, Vent	2
25	40-0300	Spring Guide	1
26	40-0323	Body, KR-150	1
27	40-0383	Ajstment Head	1
28	40-0714	Seal Container	1
29	40-0717	Piston, Manual	1
30	40-0718	Piston Guide, Manual	1
31	40-1383	Flange, Inlet & Vent	4
32	40-1384	Flange, Outlet	1
33	50-0066	Bolt, SHCS	8
34	50-0069	Bolt, SHCS	56
35	50-0239	Grip, Handle KR	3
36	50-0331	SHCS	1

PacSeal HYDRAULICS INC.

VALVES, ACCUMULATORS, CONTROLS

PROPRIETARY AND CONFIDENTIAL
 THE INFORMATION CONTAINED IN THIS DRAWING IS THE SOLE PROPERTY OF PacSeal Hydraulics. ANY REPRODUCTION IN PART OR AS A WHOLE WITHOUT THE WRITTEN PERMISSION OF PacSeal Hydraulics IS PROHIBITED.

TITLE
KR-150N5DM - Manual

SIZE A	DWG. NO. 40-1698	REV 2
SCALE: 1:5	WEIGHT: 71	SHEET 2 OF 2