

BOTTOM VIEW

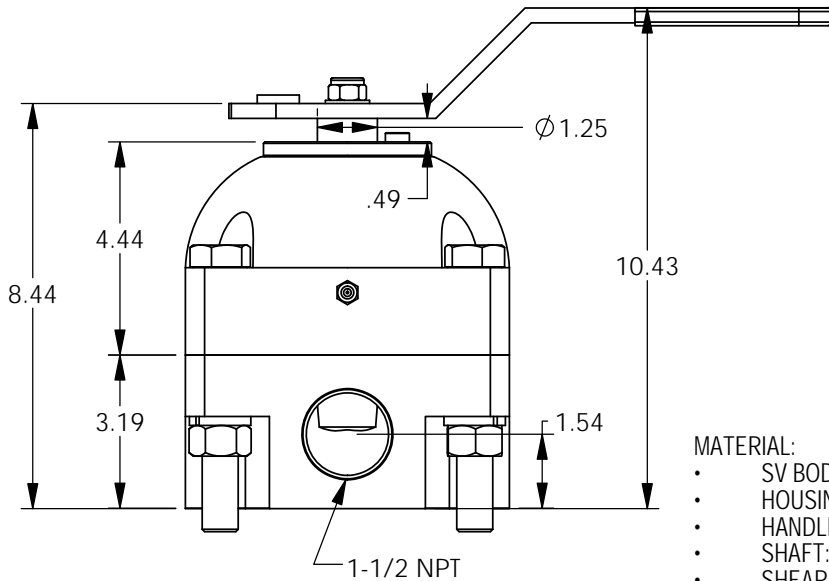

MATERIAL:

- SV BODY: 416 SS
- HOUSING: CARBON STEEL
- HANDLE, DETENT & SPACERS: PLATED CARBON STEEL
- SHAFT: 416 SS
- SHEARFLO SEALING COMPONENTS: 440c HARDENED
- O-RINGS: BUNA (NITRILE)
- BACKUPS: TEFLON

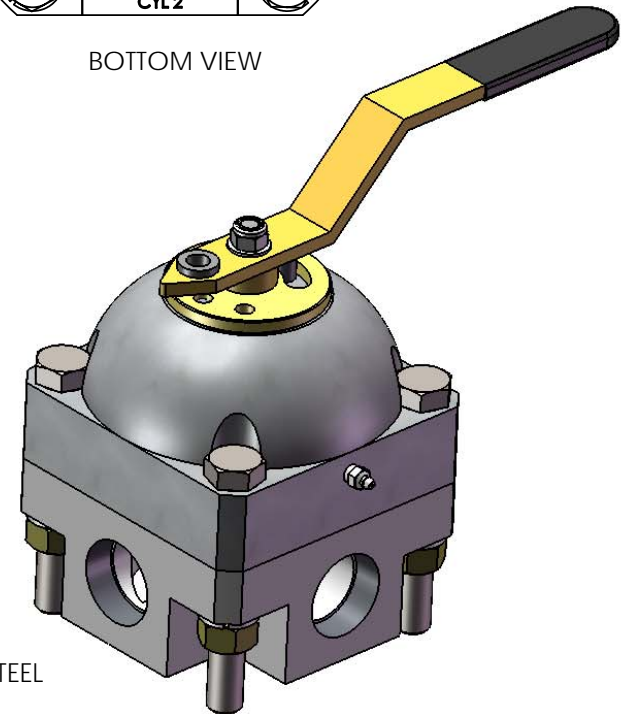

MODEL NO: **SV-150 12N5ILS1RN**
 ROTOR: Selector
 ALL PORTS: 1-1/2" NPT
 WORKING PRESSURE: 5000 PSI
 RETURN PORT: 250 PSI MAX
 Cv: 21.0
 FLOW: 180 (GPM)
 TEMP RATING: -30° TO 180°F

PROPRIETARY AND CONFIDENTIAL

THE INFORMATION CONTAINED IN THIS DRAWING IS THE SOLE PROPERTY OF PacSeal Hydraulics. ANY REPRODUCTION IN PART OR AS A WHOLE WITHOUT THE WRITTEN PERMISSION OF PacSeal Hydraulics IS PROHIBITED.

PACSEAL HYDRAULICS INC.

VALVES, ACCUMULATORS, CONTROLS

TITLE SV-150 Selector, Inline Ported	SIZE A	DWG. NO. 40-2102	REV 2
	SCALE: 1:4	WEIGHT: 64	SHEET 1 OF 2