

MATERIAL:

- SV BODY: 416 SS
- HOUSING: CARBON STEEL
- HANDLE, DETENT & SPACERS: PLATED CARBON STEEL
- SHAFT: 416 SS
- SHEARFLO SEALING COMPONENTS: 440c HARDENED
- O-RINGS: BUNA (NITRILE)
- BACKUPS: TEFLON

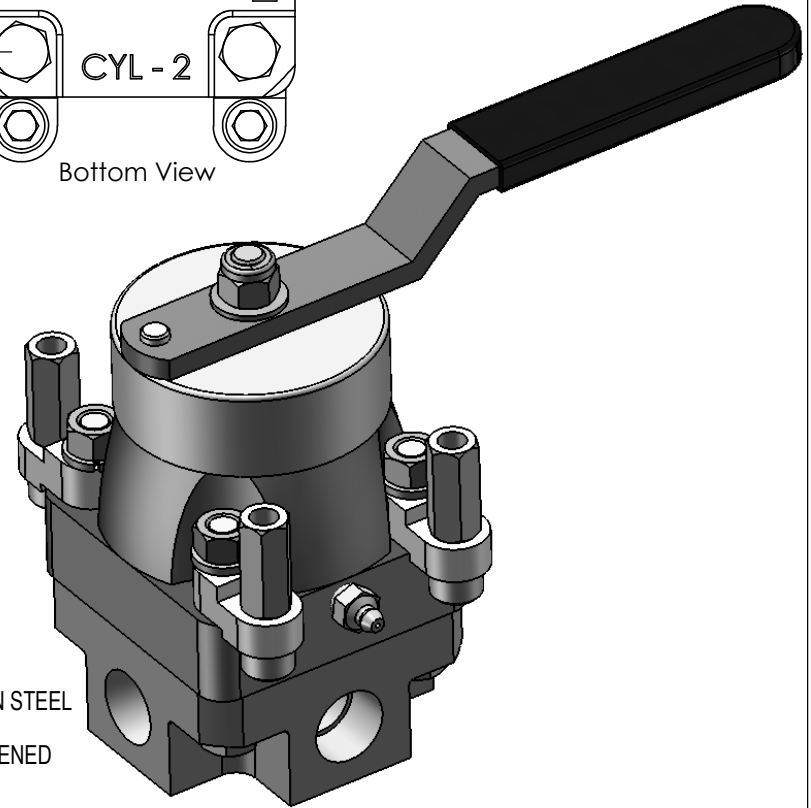

MODEL NO: **SV 50-4N6IPS1SN**
 ROTOR: Selector
 ALL PORTS: 1/2" NPT
 WORKING PRESSURE: 3000 PSI
 Cv: 3.20
 FLOW: 30 GPM
 TEMP RATING: -30°-180°F

PROPRIETARY AND CONFIDENTIAL

THE INFORMATION CONTAINED IN THIS DRAWING IS THE SOLE PROPERTY OF PacSeal Hydraulics. ANY REPRODUCTION IN PART OR AS A WHOLE WITHOUT THE WRITTEN PERMISSION OF PacSeal Hydraulics IS PROHIBITED.

PacSeal Hydraulics Inc.

VALVES, ACCUMULATORS, CONTROLS

TITLE SV-50 6K Inline Ported Spring Centered Panel Mount	SIZE	DWG. NO.	REV
	A	40-2338-PM	1
SCALE: 1:2	WEIGHT: 10	SHEET 1 OF 1	