

Only qualified personnel should perform maintenance.



Be sure that system pressure has been VENTED prior to disassembly.

All instructions, illustrations and item numbers refer to the manual operated regulator, 40-1517. Refer to specific installation drawing for corresponding items.

Repair Procedure

Preparation

1. Prepare a clean surface for disassembly, free of dust, grease, grit, etc. A vise is not necessary, but helpful. Have rags, degreasing solvent and lubricant available.
2. Critical surfaces to protect during disassembly are the inside diameter of the piston guide (25), the inside diameters of the seal container (13), the flat sealing surfaces of the seal rings (15) and (34) and the flat surfaces of the flow plates (18) and (19). Lapped surfaces should NEVER come in contact with any hard surface.
3. All O-rings and back-up rings are recommended to be replaced at a minimum. See the parts list for kit contents.
4. Special tools used in assembly include a punch for securing the pin retainer (step 3), a blunt ended rod for seating backup rings, (step 4), medium strength (blue) threadlocker (step 7) and a flat spacer about 3/16" thick for reinstalling the main and blind flanges (step 8 and 10).

Disassembly

1. To relieve the compression on the internal operator springs (27, 28) loosen the lock handle (21) and rotate the adjustment handle (22) counter-clockwise until the resistance is fully relieved. Springs must be loose to safely remove the adjustment head.



2. With a 5/16" Allen wrench, loosen and remove the socket head cap screws. Remove the adjustment head (31) and spring assembly by lifting and tilting and holding the spring plate (20) to clear the piston guide (25). Remove springs, guide and spring plate and clean barrel and all parts.
3. Remove the flange screws from the three inlet/vent flanges (32) and blind flange (33). Carefully remove these flanges and attached flow plates.
4. Remove the flow plates from the inlet/vent and blind flanges by unscrewing the bolts (37). Do not place the flow plates lapped side down on any hard surface.
5. From both sides of the body, remove the seal rings, valve cage (16) and springs from the seal container. Carefully set these aside.
6. Remove the outlet flange (24) and bottom flange (23) by removing the screws.
7. Using a soft tool, lightly tap the seal container from the bottom to loosen the piston guide from the body. Lift this assembly through the top of the body.
8. If the seal container is to be replaced, remove the piston retaining bolt (36) and piston (14). Take care not to scratch the seal container.
9. Remove all o-rings and back-up rings. Clean all parts with a degreaser and wipe with clean rags.
10. Inspect all lapped surfaces for scratches, dings or dull spots that would prevent them from re-use. Inspect the bores of the seal container for linear scratches that would propagate leaks.

Reassembly

1. Before replacing the seals and rebuilding the regulator, apply a light coating of lubricant.
2. Replace all o-rings and back-up rings on seal rings, flow plates, piston, piston guide and flanges, lubricating generously.
3. Install the piston on the seal container and tighten the retaining bolt.
4. Carefully install the valve cage, wave spring and vent seal ring from one side of the seal container, then repeat with the supply seal ring and spring. Use a soft, blunt tool to help compress the back-up ring to engage in the hole. From the opposite side, install the springs. Then install the opposite seal rings.
5. Slide the piston guide over the piston and snug it down.
6. Prior to installing the seal container, install the bottom flange (23) and its o-ring on the body and tighten all screws evenly.
7. Slide the seal container assembly down into the top of the regulator body, making sure the seal container faces are parallel with the opposing ports.
8. Install the flow plates on their respective flanges, using the screws and medium strength (blue) threadlocker. The flanges must have the o-rings seated in the face grooves before attaching the flange to the flow plates. Use rags to protect the flow plate lapped surface and edges.
9. Important! To protect the seal rings in the seal container during reassembly, ease the flow plates into one side of the body using a 3/16" thick spacer between each flange and the body to prevent over-travel.



KR-100 Manual Operated Regulator
40-1517

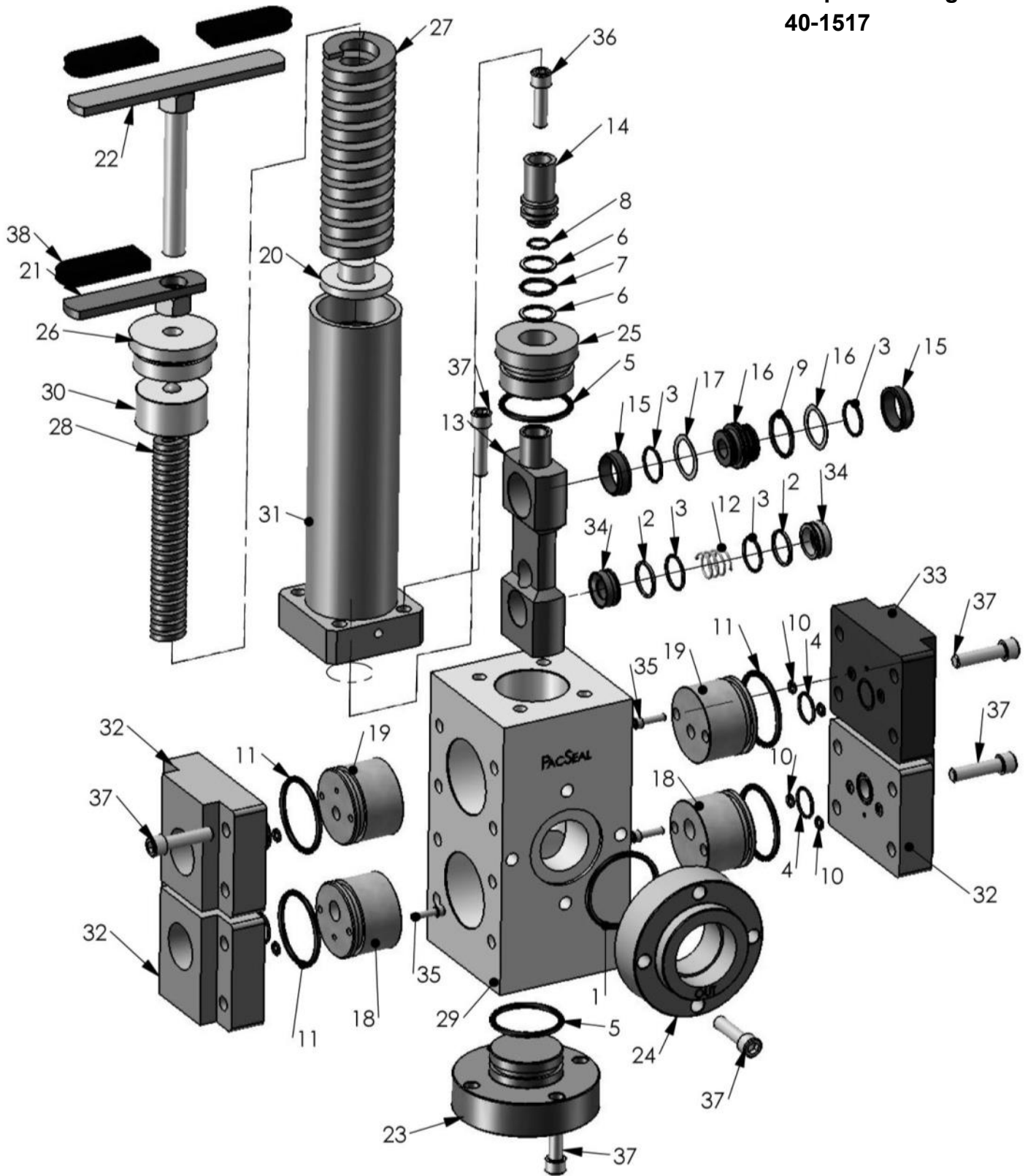

	Item	Part No.	Description	Qty	Kit
10. Insert the socket head screws and tighten evenly around each flange. The flow plates should be in light contact with the seal rings.	1	23-1126	O-Ring	1	1
	2	23-1322	Backup Ring	2	1
	3	23-1323	O-Ring	4	1
11. Important! In the same way, install the opposite flanges using the spacer to prevent the flow plate from hitting the seal rings. Orient the flange before seating it against the seal rings. Evenly tighten all socket screws.	4	23-1326	O-Ring	4	1
	5	23-1330	O-Ring	2	1
	6	23-1331	Backup Ring	2	1
	7	23-1332	O-Ring	1	1
	8	23-1333	O-Ring	1	1
	9	23-1334	O-Ring	1	1
12. Install the outlet flange and o-ring, evenly tightening all screws.	10	23-1335	O-Ring	8	1
	11	23-1336	O-Ring	4	1
13. Reassemble the springs, spring plate and guide into the barrel of the adjustment head using a light coat of grease. Lower the operator assembly with screws onto the body and evenly tighten the socket screws.	12	40-0110	Compression Spring	1	2
	13	40-0111	Seal Container	1	4
	14	40-0112	Piston	1	
	15	40-0113	Seal Ring, Vent	2	2
	16	40-0114	Valve Cage	1	3
	17	40-0115	Wave Spring	2	2
	18	40-0117	Flow Plate, Supply	2	3
	19	40-0118	Flow Plate, Vent	2	3
	20	40-0134	Spring Plate	1	
	21	40-0135	Lock Handle	1	
14. Rotate the handle down to its original position and set the lock nut. The regulator is now ready for normal operation. Some adjustment of the operator may be necessary to achieve the desired output. To increase pressure, rotate the handle clockwise, to decrease pressure rotate the screw counter-clockwise. Always tighten the lock nut after setting the regulator.	22	40-0136	Adjusting Handle	1	
	23	40-0137	Flange, Lower	1	
	24	40-0138	Flange, Outlet	1	
	25	40-0139	Piston Guide	1	
	26	40-0140	Plug, Adjustment Head	1	
	27	40-0143	Spring, Outer	1	
	28	40-0144	Spring, Inner	1	
	29	40-0148	Body	1	
	30	40-0300	Spring Guide	1	
	31	40-0388	Adjustment Head	1	
	32	40-0958	Flange, Inlet & Vent	3	
	33	40-0959	Flange, Blind	1	
	34	40-1176	Seal Ring, Supply	2	2
	35	50-0067	Bolt	8	3
	36	50-0068	Bolt	1	
	37	50-0069	Bolt	28	
	38	50-0239	Grip	3	

Kit contents:

- 1: (40-1506) O-ring Kit
- 2: (40-1589) Seal Kit, includes O-ring Kit
- 3: (40-1505) Minor Repair Kit, includes Seal Kit
- 4: (40-1556) Major Repair Kit, includes Minor Repair Kit