



Only qualified personnel should perform maintenance.

Be sure that system pressure has been VENTED prior to disassembly.

Preparation

1. Prepare a clean surface for disassembly, free of dust, grease, grit, etc. A vise is not necessary, but helpful. Have rags, degreasing solvent and lubricant available.
2. Protect the face sealing surfaces of the body 19 and housing 12, the shaft 13, thrust washer 8 and balls 10 during disassembly. Lapped surfaces of the rotor 7 and seal rings 6 should NEVER come in contact with any hard surface.
3. All O-rings and back-up rings are recommended to be replaced at a minimum. See the parts list for kit contents.

Disassembly

1. Remove the handle (15, 20, 23), spacer 17 retaining ring 16, detent disc 14, detent spring 18 and ball 11 and set aside.
2. Install in vice or other fixture with shaft end down.
3. Remove body bolts and nuts (21, 22, 24).
4. Remove body 19 and place on work bench with seal rings up. Remove seal rings 6 and wave springs 9. Take care not to damage the sealing surface of the counter-bore of the body glands.
5. Remove the rotor 7, thrust washers 8 and ball bearings 10 from the housing 12.
6. Turn the housing over with the shaft (14) up and push the shaft through the housing.

Inspection

Clean all parts thoroughly before inspection. Remove and discard all o-rings and backups.

Inspect Body:

- Port threads should be free of nicks and excessive wear.
- O-ring groove in body free of scratches and pitting.
- Seal ring gland I.D. must have no scratches and pitting.



Inspect Rotor and Seal Rings:

- Lapped surfaces must have no dull spots, pitting, scratches or undercuts.

Inspect Thrust washers and Ball Bearings:

- Groove of thrust washer should be free of pitting or scratches.
- Balls should be smooth and free of scratches or pitting.

Inspect Housing:

- No wear in shaft I.D.
- Detent ball and spring are generally reusable if not excessively corroded.
- Detent should not show wear in the detent holes or at shaft connection.
- O-ring groove in housing free of scratches and pitting.
- Grease fitting and threads are not worn or damaged.

Inspect Shaft and Handle:

- Threads on shaft are not damaged
- Shaft has no wear on the diameter where it contacts the housing.
- Check that the fit is tight between the shaft and the handle, and with the detent disk.

Reassembly

1. Before replacing the seals and rebuilding the valve, apply a light coating of lubricant.
2. Replace all o-rings and back-up rings on seal rings and shaft, lubricating generously.
3. Place the housing face up and apply lubricant to the internal surfaces of the housing. Install the o-ring in the recess above the bushing and install the shaft.
4. Place one lubricated thrust washer in the recess in the housing, and add the ball bearings, distributing evenly. Place the other well lubricated thrust washer on top of the balls.

5. Place the rotor in the housing in the orientation shown, engaging the pins into the holes on the backside of the rotor.
6. Place the body face up and install the seal rings and wave springs in each of the recesses on the body, with the lapped surface of the seal rings facing out.
7. Install the lubricated face seal o-ring on the groove on the housing. Insert the body bolts and place the assembled body on the housing, using the bolts as guides.
8. Fasten all bolts with lockwashers and nuts, torquing evenly.
9. Grease the detent spring hole on the top of the housing, insert the spring and ball, and install the detent disc. Replace the retaining ring and install the spacer and handle.

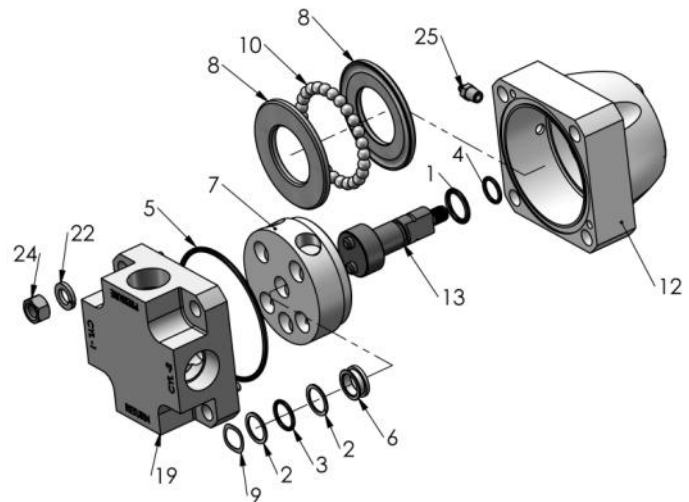

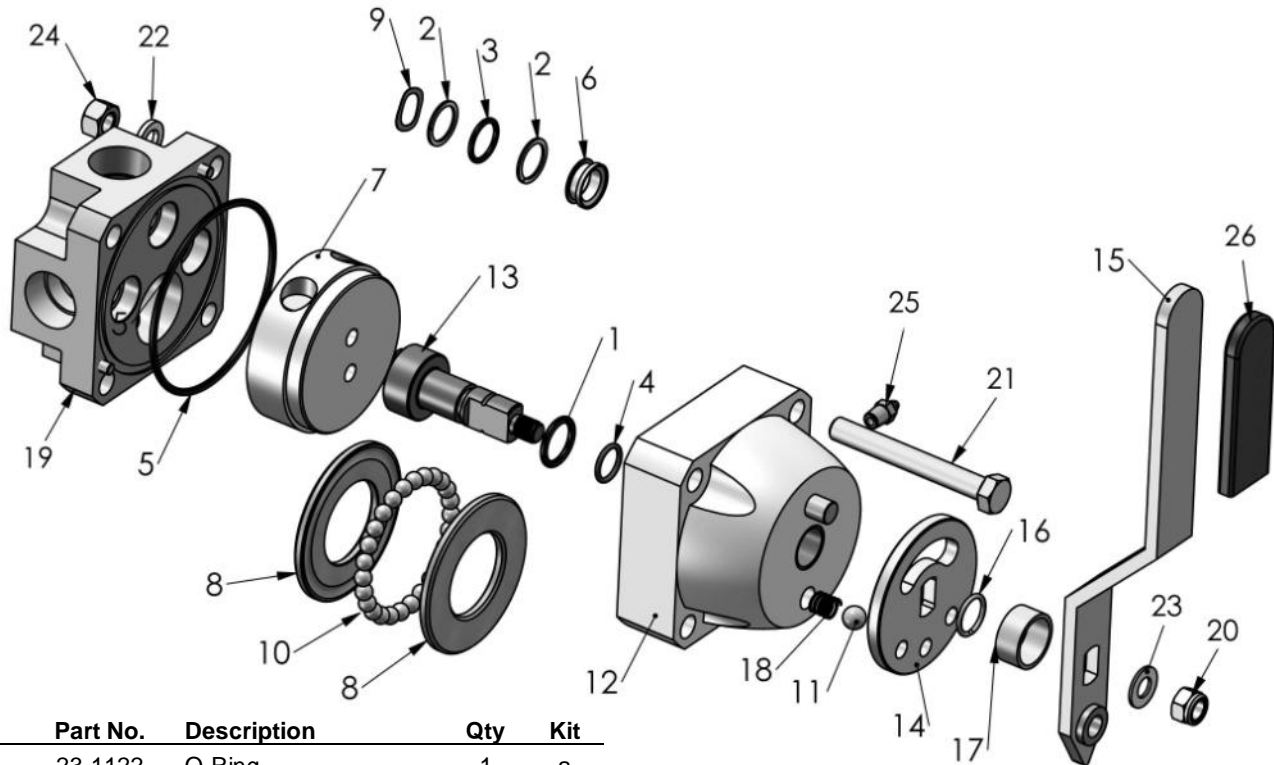

#	Part No.	Description	Qty	Kit
1	23-1122	O-Ring	1	a
2	23-1331	Back-Up Ring	6	a
3	23-1332	O-Ring	3	a
4	23-1352	O-Ring	1	a
5	23-1363	O-Ring	1	a
6	40-0007	Seal Ring	3	b
7	Tabulated	Rotor	1	c
8	40-0009	Thrust Washer	2	d
9	40-0027	Wave Spring	3	b
10	40-0049	Ball Bearing	26	d
11	40-0174	Detent Ball	1	
12	40-0175	Housing	1	
13	40-0178	Shaft	1	
14	40-0180	Detent Disc	1	
15	40-0284	Handle	1	
16	40-0288	Retainer Ring	1	
17	40-0773	Spacer	1	
18	40-0295	Spring, Detent	1	
19	40-0982	Body, 1" NPT	1	
20	50-0093	Shaft Locknut	1	
21	50-0100	Body Bolt	4	
22	50-0104	Lock Washer	4	
23	50-0108	Shaft Washer	1	
24	50-0110	Body Nut	4	
25	50-0176	Grease Fitting	1	
26	50-0236	Grip	1	

Kit contents:

- a: O-ring Kit
- b: Seal Kit, includes O-ring Kit
- c: Minor Repair Kit, includes Seal Kit
- d: Major Repair Kit, includes Minor Repair Kit

Part No.	Description
40-0008	Rotor, Selector
40-0130	Rotor, Bypass
40-0223	Rotor, Manipulator
40-0358	Rotor, Open Center

Maintenance

ShearFlo® Valves require little maintenance other than the inspections and refurbishment described here, dependent on usage and system condition.

Valves in water service can be lubricated by applying grease at the grease fitting located on the housing. Use a water resistant lubricant. If water soluble oil is used in the hydraulic system, greasing is not generally required.