

PacSeal HYDRAULICS INC.

VALVES, ACCUMULATORS, CONTROLS

PROPRIETARY AND CONFIDENTIAL
 THE INFORMATION CONTAINED IN THIS DRAWING IS THE SOLE
 PROPERTY OF PacSeal Hydraulics.
 ANY REPRODUCTION IN PART OR AS A WHOLE WITHOUT THE
 WRITTEN PERMISSION OF PacSeal Hydraulics IS PROHIBITED.

TITLE	AAC-202 Air Actuator Cylinder Assembly - 2"	SIZE	DWG. NO.	REV
		A	40-4191	1
		SCALE: 1:2	WEIGHT:	SHEET 1 OF 2

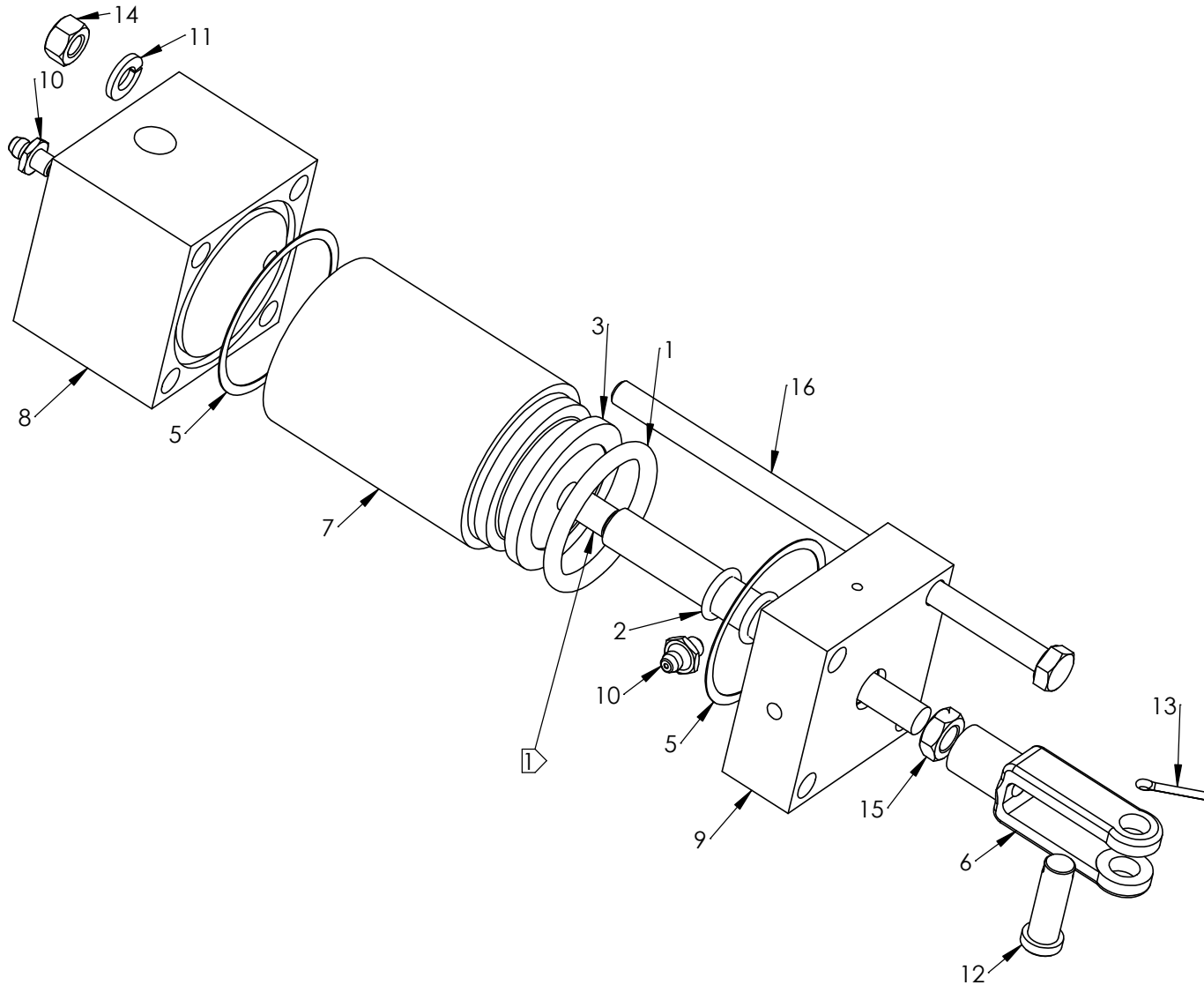

ITEM NO.	PART NUMBER	DESCRIPTION	QTY.
1	23-1121	O-Ring	1
2	23-1337	O-Ring	2
3	40-0612	Piston, AAC-202	1
4	40-0613	Shaft, AAC-202	1
5	40-0619	Gasket	2
6	40-0620	Clevis, AAC-202	1
7	40-2564	Cylinder	1
8	40-4189	Cylinder Head, Swivel End	1
9	40-4190	Cylinder Head Rod End Assembly	1
10	50-0120	1/4" Zerk Fitting	2
11	50-0142	Lock Washer	4
12	50-0195	Clevis Pin	1
13	50-0196	Cotter Pin	1
14	50-0246	Hex Nut	4
15	50-0336	Jam Nut	1
16	50-0611	Hex Head Bolt	4

NOTES:

1 APPLY BLUE THREADLOCKER BETWEEN SHAFT AND PISTON

PROPRIETARY AND CONFIDENTIAL
 THE INFORMATION CONTAINED IN THIS DRAWING IS THE SOLE PROPERTY OF PacSeal Hydraulics. ANY REPRODUCTION IN PART OR AS A WHOLE WITHOUT THE WRITTEN PERMISSION OF PacSeal Hydraulics IS PROHIBITED.

PacSeal Hydraulics Inc.

VALVES, ACCUMULATORS, CONTROLS

TITLE	AAC-202 Air Actuator Cylinder Assembly - 2"	SIZE	DWG. NO.	REV
		A	40-4191	1
SCALE: 1:2	WEIGHT:	SHEET 2 OF 2		