

-	-	-
REV	ECN	DATE

PACSEAL HYDRAULICS INC.

VALVES, ACCUMULATORS, CONTROLS

PROPRIETARY AND CONFIDENTIAL
 THE INFORMATION CONTAINED IN THIS DRAWING IS THE SOLE PROPERTY OF PacSeal Hydraulics. ANY REPRODUCTION IN PART OR AS A WHOLE WITHOUT THE WRITTEN PERMISSION OF PacSeal Hydraulics IS PROHIBITED.

TITLE Failsafe Air Actuator,
 KR Universal
 HP Output

SIZE A	DWG. NO. 40-4280	REV 1
SCALE: 1:4	WEIGHT: 52	SHEET 1 OF 2

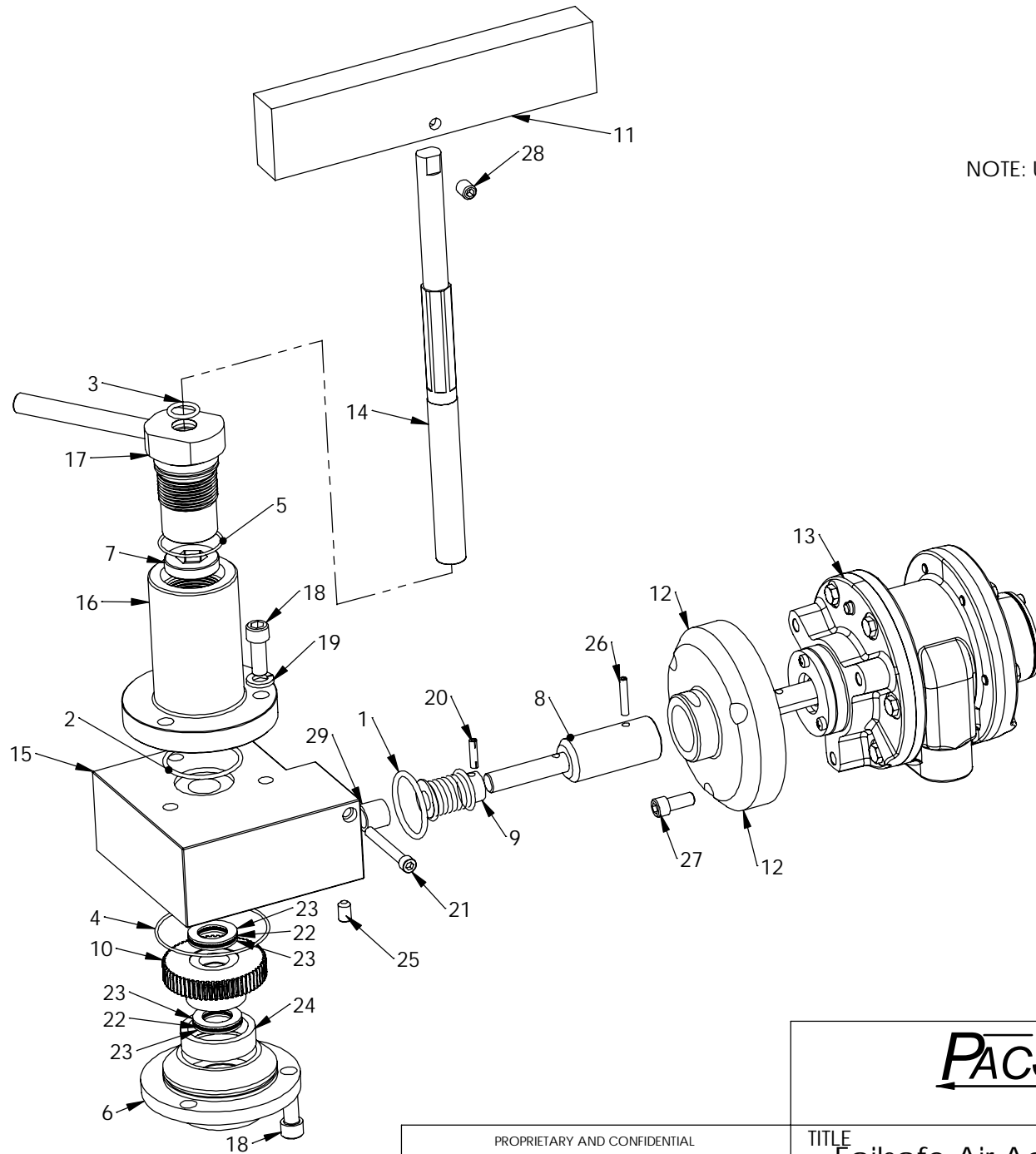

NOTE: USE TOOL 41-0089 TO INSTALL #29 ROLLER BEARING

ITEM NO.	PART NUMBER	DESCRIPTION	QTY.
1	23-1123	O-Ring	1
2	23-1356	O-Ring	1
3	23-1385	O-Ring	1
4	23-1404	O-Ring	1
5	23-1405	O-Ring	1
6	40-0414	ADAPTER PLATE, KR-FAILSAFE	1
7	40-0416	Fail Safe Collar	1
8	40-0716	Fail Safe Shaft Extension-Hydraulic	1
9	40-2742	Worm, FS-HP Actuator	1
10	40-2743	Worm Gear, FS-HP	1
11	40-3237	Handle, Fail Safe HP	1
12	40-3757	Adapter Plate, KR Actuator	1
13	40-3761	Air Motor Modification	1
14	40-3960	Fail Safe Shaft, KR	1
15	40-3961	Fail Safe Body	1
16	40-3962	Housing, KR-Shaft Adjustment	1
17	40-3964	Fail Safe Nut Assy	1
18	50-0072	SHCS	6
19	50-0103	Lock Washer	3
20	50-0154	Roll Pin	1
21	50-0156	SHCS, 1/4-20UN	1
22	50-0157B	Bearing, NTA-1220	2
23	50-0157T	Thrust Washer, TRB-1220	4
24	50-0158	Roller Bearing	1
25	50-0223	Hex Socket Set Screw	2
26	50-0287	ROLL PIN, 3/16" X 1" LG	1
27	50-0319	SHCS	3
28	50-0482	Set Screw, Cup Point	2
29	50-0483	Roller Bearing	1

PACSEAL HYDRAULICS INC.

VALVES, ACCUMULATORS, CONTROLS

PROPRIETARY AND CONFIDENTIAL
 THE INFORMATION CONTAINED IN THIS DRAWING IS THE SOLE PROPERTY OF PacSeal Hydraulics. ANY REPRODUCTION IN PART OR AS A WHOLE WITHOUT THE WRITTEN PERMISSION OF PacSeal Hydraulics IS PROHIBITED.

TITLE	SIZE	DWG. NO.	REV
Failsafe Air Actuator, KR Universal HP Output	A	40-4280	1
SCALE: 1:4		WEIGHT: 52	SHEET 2 OF 2