

Only qualified personnel should perform maintenance.



Be sure that system pressure has been VENTED prior to disassembly.

All instructions, illustrations and item numbers in this document classify the KR-38 "H" manual operated regulator. Refer to specific installation drawing for corresponding items.

Repair Procedure

Preparation

1. Prepare a clean surface for disassembly; free of dust, grease, grit, etc. A vise is not necessary, but helpful. Have rags, degreasing solvent and lubricant available.
2. Critical surfaces to protect during disassembly are the inside diameter of the Piston Guide (19), the inside diameters of the Seal Container (29), the lapped sealing surfaces of the Seal Rings (21 and 22) and the lapped surfaces of the Flow Plates (27 and 28). Lapped surfaces must always be stored facing up and must NEVER come in contact with any hard surface.
3. All O-rings and back-up rings are recommended to be replaced at the very least. See the parts list for kit contents.
4. Standard tools required are a 5/16" hex key, 5/32" hex key, wire cutters, hammer, and punch.
5. Special tools used in "Reassembly" are: a blunt ended rod for seating back-up rings (Step 3), medium strength (blue) threadlocker (Step 7), and a flat spacer about 3/32" thick for assembling the Supply and Vent Flanges (Step 8 and 10).



Disassembly

1. To relieve the compression on the internal operator springs (17 and 18) loosen the Lock Handle (14) and rotate the Adjusting Handle (15) counter-clockwise (up) until the resistance is fully relieved. Springs must be loose to safely remove the Adjustment Head (26).
2. With a 5/16" hex key, loosen and remove the socket head cap screws (34) affixing the Adjustment Head. Remove the Adjustment Head/internal operator assembly by lifting, tilting and holding the Spring Plate (13) to clear the Piston Guide (19). Remove the Springs (17 and 18), Thrust Bearing Assembly (33) and Spring Plate (13). Clean barrel and all parts.
3. Remove the screws (34) from the Supply and Vent Flanges (30 and 31) using a 5/16" hex key. Carefully remove said Flanges and attached Flow Plates.
4. Remove the Flow Plates from the Supply and Vent Flanges by unfastening the screws (35) using a 5/32" hex key. **Always store Flow Plates with lapped surface facing UP.**
5. From both sides of the Body, remove the Seal Rings and Springs. **Always store Seal Rings with lapped surface facing UP.**
6. Unfasten the remaining screws holding the Lower Flange (23) and remove said Flange.
7. Using a soft tool, lightly tap the bottom of the Seal Container (29) to loosen the Piston Guide (19) from the Body. Lift this assembly through the top of the Body.
8. Remove all O-rings and back-up rings (to be discarded). Clean all parts with a degreaser and wipe with clean rags.
9. Inspect all lapped surfaces for scratches, dings or dull spots that would prevent them from reuse. Inspect the bores of the Body and Piston Guide for linear scratches that would propagate leaks.

Reassembly

1. Before replacing the seals and rebuilding the regulator, apply a light coating of lubricant to all O-ring grooves.
2. Replace all O-rings and back-up rings on Seal Rings, Flow Plates, Piston, Piston Guide and Flanges, lubricating generously.
3. Ensure that the back-up rings are installed closest to the sealing/lapped surface of the Supply Seal Rings.
4. Carefully install two Supply and one Vent Seal Ring on the SUPPLY side ONLY of the Seal Container, which has the protrusion. Push the Seal Rings in the Seal Container so that the Seal Rings are nearly flush with the (protrusion) surface of the Seal Container. If the back-up ring catches, then use a soft and blunt tool to help compress it around the Supply Seal Ring while installing it in the Seal Container.
5. Slide the Piston Guide over the piston end of the Seal Container until it is snug with the O-ring and Back-up rings of the piston.
6. Slide the Seal Container (with Seal Rings on supply side only) down into the top of the regulator Body, making sure the Seal Container faces are parallel with the opposing ports. Note that the PROTRUSION side of the Seal Container must face the supply side.
7. Install the Flow Plates with lubricated O-ring (11) on their respective Flanges with the screws and medium strength (blue) thread locker. The Flanges also must have the O-rings (5 and 6) seated in the face grooves before fastening to the Flow Plates. Use rags to protect the Flow Plate lapped surface

and edges.

8. Important! Supply side parts must be installed first. To protect the Seal Rings in the Seal Container during reassembly, ease the SUPPLY Flow Plate into the Body using a 3/32" thick spacer between said Flange and the Body to prevent over-travel, as shown in the image below. Align the Flange so that the two inlet ports of the Supply Flow Plate are oriented toward the top of the

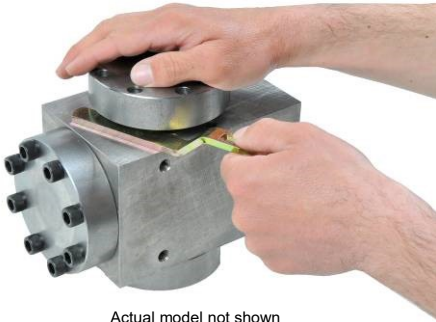

Actual model not shown

regulator.

9. From the vent side, carefully install the Springs and opposite lubricated Seal Rings (do not scratch the sealing surface of the Seal Ring or the bore of the Seal Container) into the Seal Container.
10. Important! In the same manner as step 8, install the other Flange using the 3/32" thick spacer to prevent the Vent Flow Plate from hitting the Seal Rings, as shown in the above image. Align the Flange such that the vent port is oriented towards the bottom of the regulator.
11. Insert the screws into the Supply and Vent Flanges. Tighten the screws evenly around the Flange in a star pattern, and alternate between the Flanges such that they approach contact with the Body at the same time. The Flow Plate should be in light

contact with the Seal Rings.

12. Install the Bottom Flange with the O-ring, evenly tightening all screws.
13. Reassemble the Springs (17 and 18), Spring Plate (13) and Thrust Bearing Assembly (33) into the barrel of the Adjustment Head using a light coat of grease. Lower the operator assembly with screws onto the Body and evenly tighten the socket screws.
14. Rotate the Handle down to its original position and tighten the Locking Handle to it. The regulator is now ready for normal operation. Some adjustment of the operator may be necessary to achieve the desired output. To increase or decrease pressure, rotate the Adjusting Handle clockwise or counter-clockwise, respectively. Always tighten the Locking Handle to the Adjusting Handle after setting the regulator.

Maintenance

ShearFlo® Regulators require little maintenance other than the inspections and refurbishment described here, dependent on usage and system condition.

MAINTENANCE INSTRUCTIONS

KR-38 Regulator



Kit Key	Kit Description	Kit Part No.
a	O-ring Kit	40-1595
b	Seal Kit	40-1594
c	Minor Repair Kit	40-1593
d	Major Repair Kit	40-1592

Item No.	Part No.	Description	Qty	Kit
1	23-1141	O-Ring	1	a
2	23-1325	O-Ring	1	a
3	23-1331	Back-up Ring	2	a
4	23-1332	O-Ring	1	a
5	23-1333	O-Ring	1	a
6	23-1335	O-Ring	8	a
7	23-1338	O-Ring	1	a
8	23-1344	O-Ring	2	a
9	23-1345	Back-up Ring	4	a
10	23-1400	O-Ring	2	a
11	23-1433	Back-up Ring	1	a
12	40-0134	Spring Plate	1	
13	40-0135	Lock Handle	1	
14	40-0136	Adjusting Screw & Handle	1	
15	40-0140	Plug, Adjustment Head	1	
16	40-0143	Spring, Outer	1	
17	40-0144	Spring, Inner	1	
18	40-0330	Piston Guide	1	
19	40-0332	Spring	2	b
20	40-0334	Seal Ring, Vent	2	b
21	40-0336	Seal Ring, Supply	4	b
22	40-0339	Flange, Lower	1	
23	40-0341	Body	1	
24	40-0345	Adapter	1	
25	40-0388	Adjustment Head	1	
26	40-0396	Flow Plate, Supply	1	c
27	40-0397	Flow Plate, Vent KR-38	1	c
28	40-0398	Seal Container	1	d
29	40-0399	Flange, Supply	1	
30	40-0400	Flange, Vent	1	
31	40-0863	Spring	1	b
32	40-3857	Thrust Bearing Assembly	1	
33	50-0069	Bolt, SHCS	22	
34	50-0084	SHCS	4	b
35	50-0239	Grip, Handle	3	

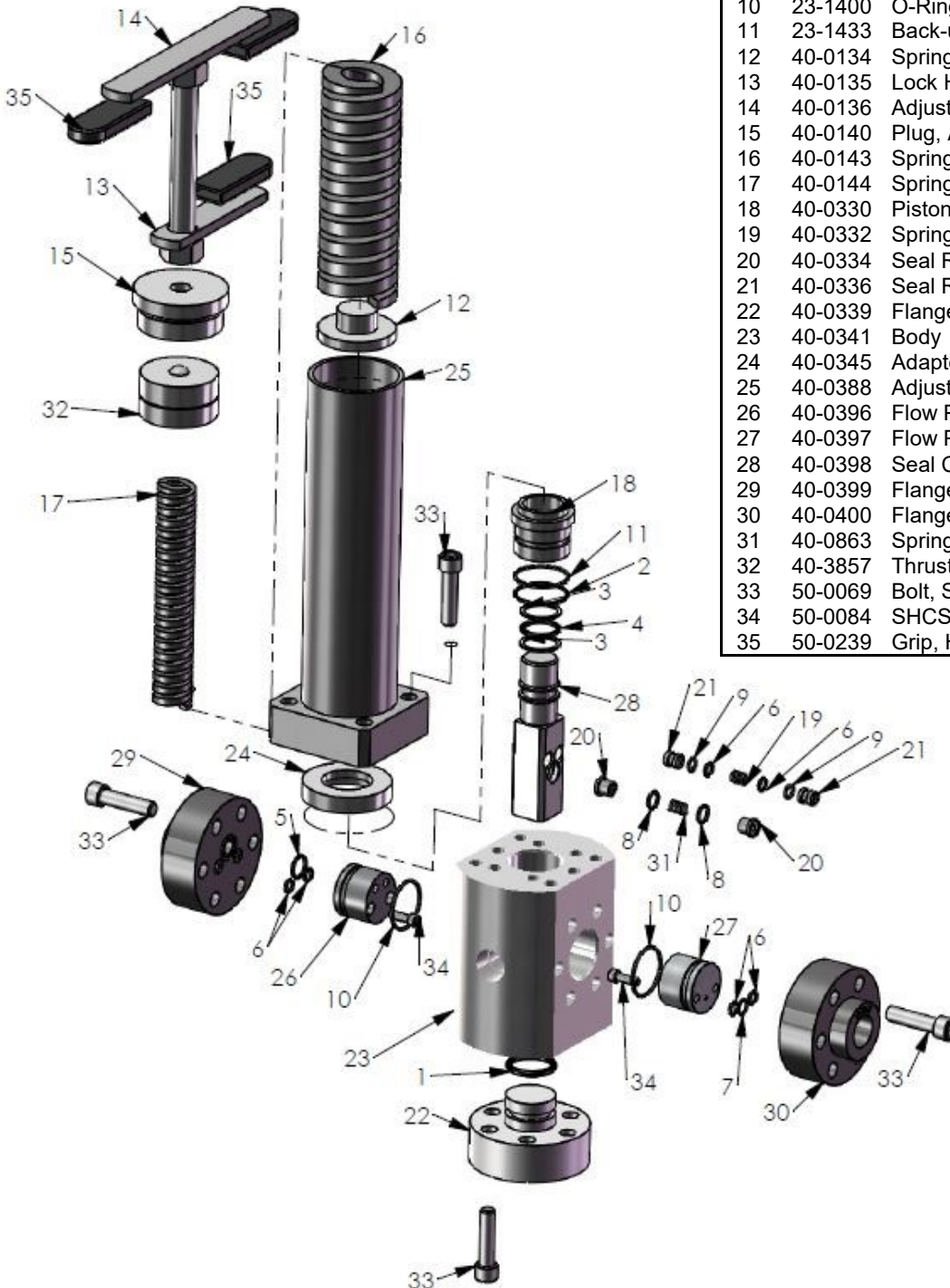

Rev F

Tel: 714-529-9495

Fax: 714-529-1366

PACSEAL HYDRAULICS, INC.

561 Tamarack Ave, Brea CA 92821 USA

pacsealhydraulics.com