

- Slide: 2-Position (OPEN - CLOSE)
- (2) MP LF9 Ports
- Working Pressure: 20k
- Internal orifice: .3
- Flow: 15 GPM

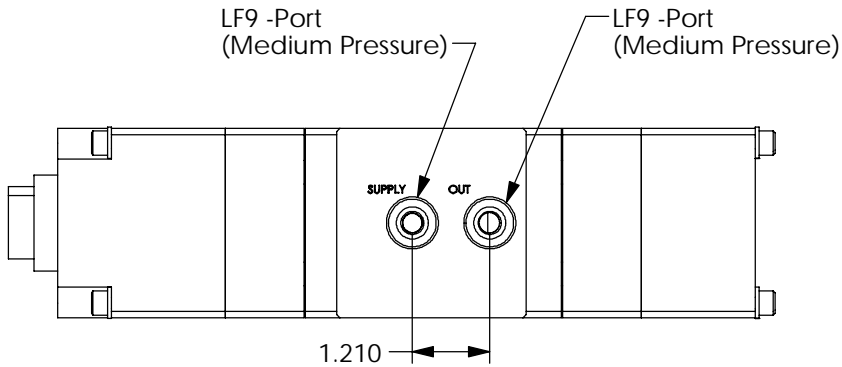
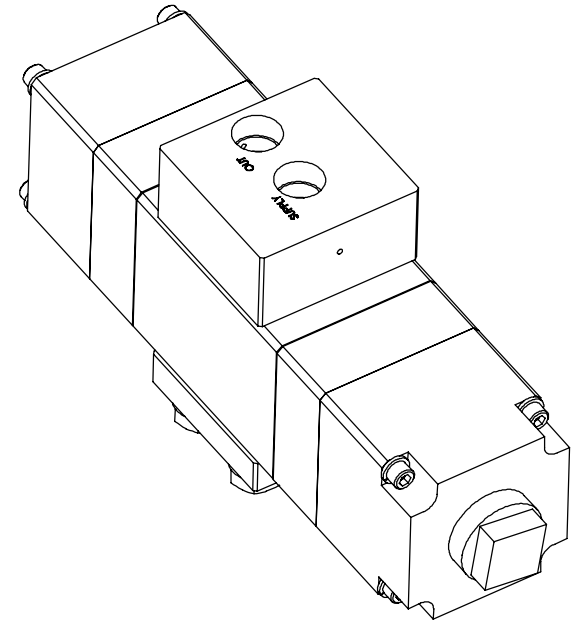
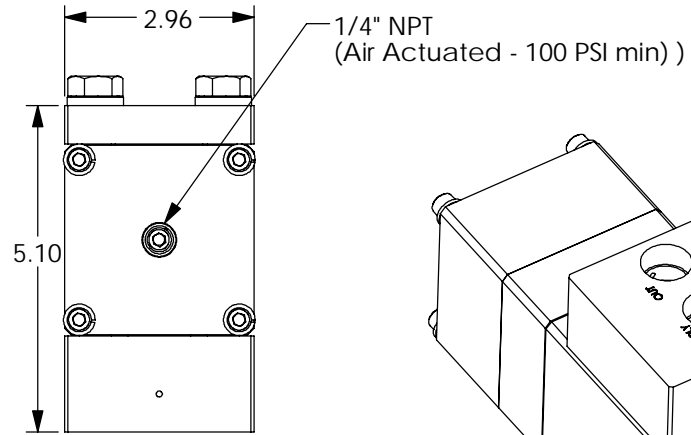
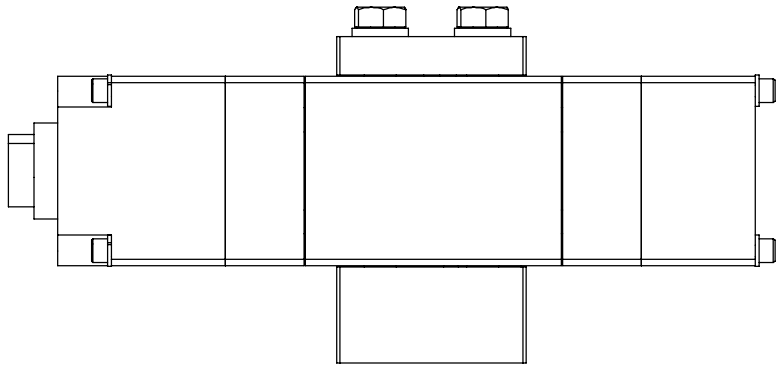

PROPRIETARY AND CONFIDENTIAL
 THE INFORMATION CONTAINED IN THIS DRAWING IS THE SOLE
 PROPERTY OF PacSeal Hydraulics.
 ANY REPRODUCTION IN PART OR AS A WHOLE WITHOUT THE
 WRITTEN PERMISSION OF PacSeal Hydraulics IS PROHIBITED.

PACSEAL HYDRAULICS INC.

VALVES, ACCUMULATORS, CONTROLS

TITLE	SIZE	DWG. NO.	REV
Grease Valve, 20k Air Actuated - Spring Return	A	40-4434	3
SCALE: 1:3	WEIGHT: 3	SHEET 1 OF 2	