

**Only qualified personnel should perform maintenance.**



**Be sure that system pressure has been VENTED prior to disassembly.**

*All instructions, illustrations and item numbers classify the manual operated regulator, KR-75 "R". Refer to specific installation drawing for corresponding items.*

## Repair Procedure

### Preparation

1. Prepare a clean surface for disassembly; free of dust, grease, grit, etc. A vise is not necessary, but helpful. Have rags, degreasing solvent and lubricant available.
2. Critical surfaces to protect during disassembly are the inside diameter of the Piston Guide (24), the inside diameters of the Seal Container (16), the lapped sealing surfaces of the Seal Rings (12 and 13) and the lapped surfaces of the Flow Plates (14 and 15). Lapped surfaces must always be stored facing up and must NEVER come in contact with any hard surface.
3. All O-rings and back-up rings are recommended to be replaced at the very least. See the parts list for kit contents.
4. Standard tools required are a 5/16" hex key, 3/16" hex key, wire cutters, hammer, and punch.
5. Special tools used in "Reassembly" are: a blunt ended rod for seating back-up rings (Step 4), medium strength (blue) threadlocker (Step 7), and a flat spacer about 3/32" thick for assembling the Main and Blind Flanges (Steps 8 and 10).



## Disassembly

1. To relieve the compression on the internal operator springs (25 and 26) loosen the Locking Handle (21) and rotate the Adjusting Handle (22) counter-clockwise (up) until the resistance is fully relieved. Springs must be loose to safely remove the Adjustment Head (34).
2. With a 5/16" hex key, loosen and remove the socket head cap screws (37) affixing the Adjustment Head. Remove the Adjustment Head/internal operator assembly by lifting, tilting and holding the Spring Plate (20) to clear the Piston Guide (24). Remove the Springs (25 and 26), Spring Guide (33) and Spring Plate. Clean barrel and all parts.
3. Remove the screws (37) from the Blind and Main Flanges (27 and 30) using a 5/16" hex key. Carefully remove said Flanges and attached Flow Plates.
4. Remove the Flow Plates (14 and 15) from the Flanges by unfastening the screws (35) with a 3/16" hex key. **Always store Flow Plates with lapped surface facing UP.**
5. From both sides of the Body, remove the Seal Rings (12 and 13) and Springs (18 and 19) from the Seal Container (16). Carefully set these aside. **Always store Seal Rings with lapped surface facing UP.**
6. Unfasten the remaining screws holding the Lower Flange (29) and Outlet Flange (26) and remove said flanges.
7. Using a soft tool, lightly tap the bottom of the Seal Container to loosen the Piston Guide (24) from the Body. Lift this assembly through the top of the Body.
8. If the Seal Container is to be replaced, remove the Pin Retainer (31) by cutting through it with a screw driver or wire cutters. Take care not to scratch the Piston.
9. Remove all O-rings and back-up rings (to be discarded). Clean all parts with a degreaser and wipe with clean rags.
10. Inspect all lapped surfaces for scratches, dings or dull spots that would prevent them from reuse. Inspect the bores of the Seal Container, Body, and Piston Guide for linear scratches that would propagate leaks.

## Reassembly

1. Before replacing the seals and rebuilding the regulator, apply a light coating of lubricant to all O-ring grooves.
2. Replace all O-rings and back-up rings on Seal Rings, Flow Plates, Piston, Piston Guide and Flanges, lubricating generously.
3. If the Seal Container is to be replaced; install the Piston (17) on the Seal Container, insert the Pin (38), then slide the new Pin Retainer (31) over the Piston. With a punch and hammer, crimp the Pin Retainer at both sides opposite the ends of the Pin.
4. Install the Seal Rings from one side of the Seal Container, ensuring to take care to not scratch the sealing surfaces of both parts. If the back-up ring catches, then use a soft and blunt tool to help compress it around the Seal Ring while installing it in the Seal Container. From the opposite side, install the remaining Wave and Compression Spring (18 and 19) before installing the final Seal Rings.
5. Slide the Piston Guide over the Piston until it is snug with the O-ring and back-up rings of the Piston.
6. Slide the Seal Container assembly down into the top of the Body, making sure that the Seal Container faces are parallel with the opposing ports. Note that the scalloped side of the Seal Container must face the supply side (i.e. Main Flange (30)).

7. Install the Flow Plates with lubricated O-rings (1) on their respective Flanges, using the screws (35) and medium strength (blue) threadlocker. The Main Flange (30) must have the O-rings (9 and 10) seated in the face grooves before fastening to the Supply Flow Plate. Use rags to protect the lapped surface and edges of the Flow Plate.
8. Important! To protect the Seal Rings in the Seal Container during reassembly, ease the Blind Flow Plate (with Flange) into the Body using a 3/16" thick spacer between the Flange and the Body to prevent over-travel. Orient the Blind Flange so that the screws (35) are parallel with the bottom of the Body. Remove the spacer.



9. Insert the screws (37) and tighten evenly around the Blind Flange in a star pattern. The Flow Plate should be in light contact with the Seal Rings.
10. Important! In the same manner as Step 8, install the Main Flange using the spacer to prevent the Supply Flow Plate from hitting the Seal Rings. Orient the Flange before seating it against the Seal Rings. The inlet port of the Main Flange must be vertical. Evenly tighten all screws using a star pattern.
11. Install the Outlet Flange and Bottom Flange with their O-rings (3 and 8), evenly tightening all screws.

12. Reassemble the internal operator Springs, Spring Plate, and Spring Guide into the barrel of the Adjustment Head using a light coat of grease. Lower the operator assembly with screws onto the body and evenly tighten the screws.
13. Rotate the Handle down to its original position and tighten the Locking Handle to it. The regulator is now ready for normal operation. Some adjustment of the operator may be necessary to achieve the desired output. To increase or decrease pressure, rotate the Adjusting Handle clockwise or counter-clockwise, respectively. Always tighten the Locking Handle to the Adjusting Handle after setting the regulator.

## Maintenance

ShearFlo® Regulators require little maintenance other than the inspections and refurbishment described here, dependent on usage and system condition.

Item No.	Part No.	Description	Qty	Kits
1	23-1263	O-ring	2	a
2	23-1293	O-ring	2	a
3	23-1319	O-ring	2	a
4	23-1320	Back-Up Ring	2	a
L4	23-1342	Back-Up Ring	2	a
D4	23-1331	Back-Up Ring	2	a
5	23-1321	O-ring	1	a
L5	23-1124	O-ring	1	a
D5	23-1332	O-ring	1	a
6	23-1322	Back-Up Ring	4	a
7	23-1323	O-ring	4	a
8	23-1324	O-ring	1	a
9	23-1325	O-ring	1	a
10	23-1326	O-ring	1	a
11	23-1329	Back-Up Ring	2	a
P	23-1123	O-ring	1	a
P	23-1327	O-ring	1	a
P	23-1328	Back-Up Ring	2	a

Item No.	Part No.	Description	Qty	Kits
12	40-0013	Seal Ring, Vent	2	b
13	40-0014	Seal Ring, Supply	4	b
14	40-0015	Flow Plate, Blind	1	c
15	40-0016	Flow Plate, Supply	1	c
16	40-0106	Seal Container	1	d
Alt16	40-0182	Seal Container	1	e
17	40-0107	Piston *	1	
18	40-0109	Wave Spring	1	b
19	40-0110	Spring	2	b
20	40-0134	Spring Plate	1	
21	40-0135	Locking Handle	1	
22	40-0136	Adj Screw & Handle	1	
23	40-0140	Sealing Plug	1	
24	40-0186	Piston Guide *	1	
25	40-0189	Compression Spring, Outer	1	
26	40-0190	Compression Spring, Inner	1	
27	40-0195	Flange, Blind	1	
28	40-0196	Flange, Outlet	1	
29	40-0197	Flange, Lower	1	
30	40-0198	Flange, Main	1	
31	40-0199	Pin Retainer	1	d
32	40-0200	Body	1	
33	40-0300	Spring Guide	1	
34	40-0383	Adjustment Head	1	
35	50-0066	Screw	4	b
36	50-0068	Screw	6	
37	50-0069	Screw	32	
38	50-0087	Pin	1	d
Alt38	50-0117	Poll Pin	1	e

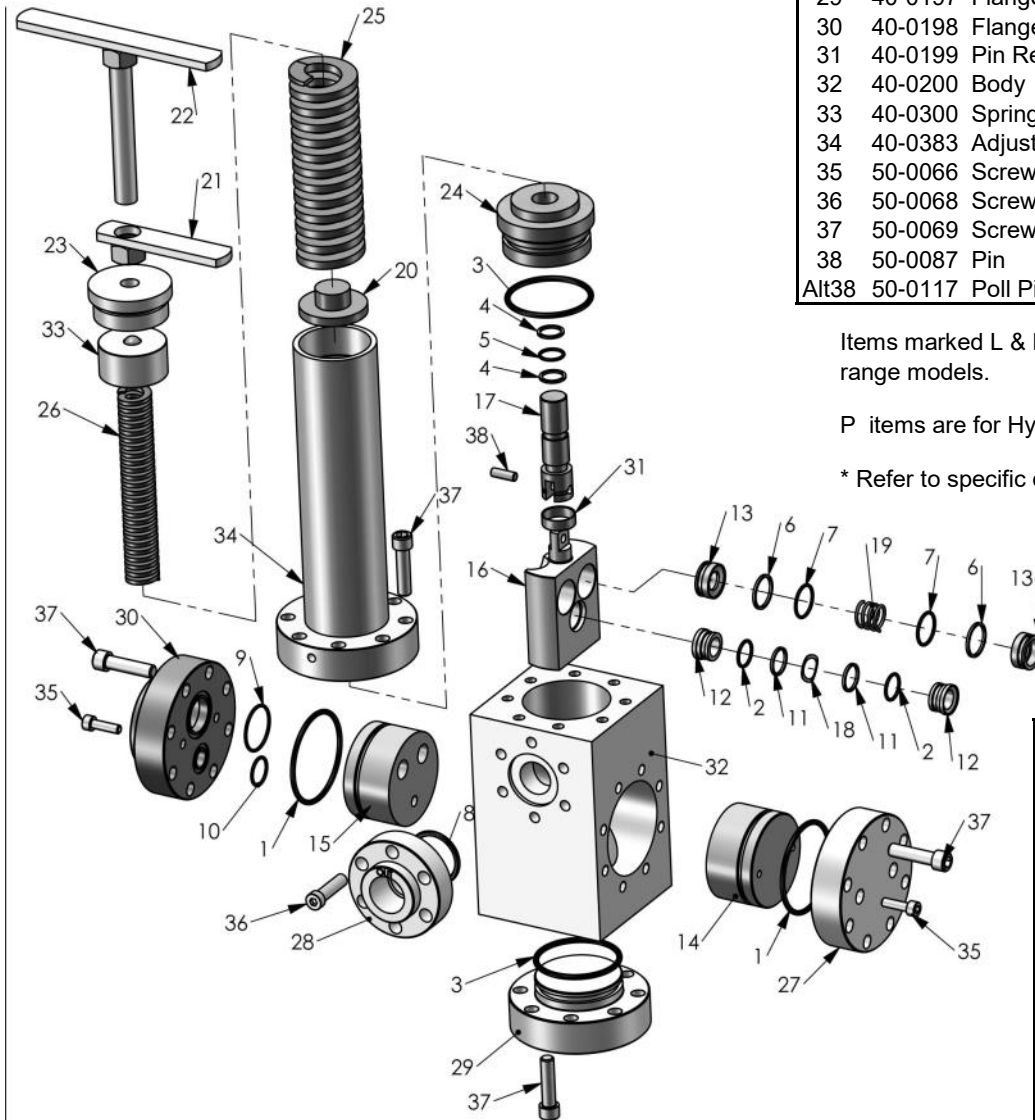

Items marked L & D refer to alternate output range models.

P items are for Hydraulic pilot and are not shown

\* Refer to specific drawing for alternates.

Kit	Kit Description	Kit Part No.
a	O-ring Kit	40-1504
b	Seal Kit (incl a)	40-1590
c	Minor Repair Kit (incl a,b)	40-1503
d	Major Repair Kit (R,V) (incl a,b,c)	40-1566
e	Major Kit (L,D,W,P) (incl a,b,c)	40-1819