

NEUTRAL POSITION

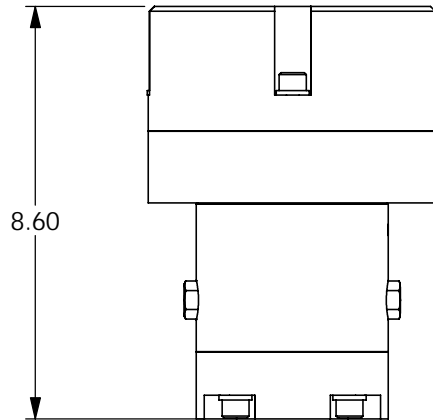
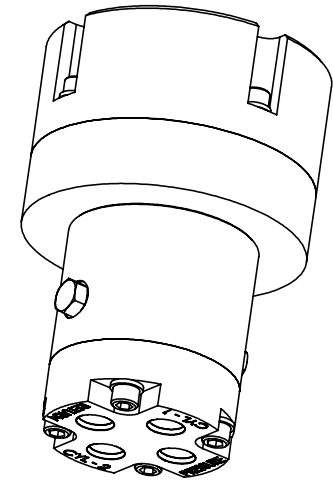
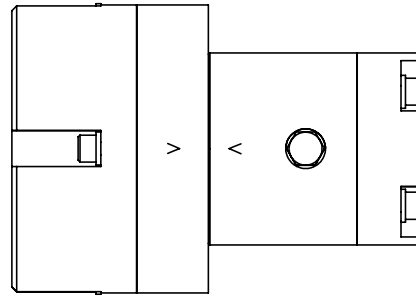

-W.P. : 6000 PSI ON PORTS: P, C1 & C2  
RETURN PORT: 250 PSI MAX DIFF. FROM  
AMBIENT/ EXTERNAL PRESSURE

-SERVICE: SUBSEA SERVICE

-MATERIALS:  
EXTERNAL: 316 SS  
INTERNAL (SEALING): 440c, 316  
INTERNAL (NON SEALING): BRONZE  
-ELASTOMERS: NITRILE, TEFLON

-MAX ACTUATION TORQUE: 15 ft\*lbs

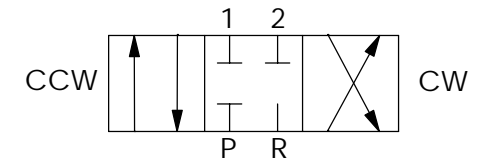
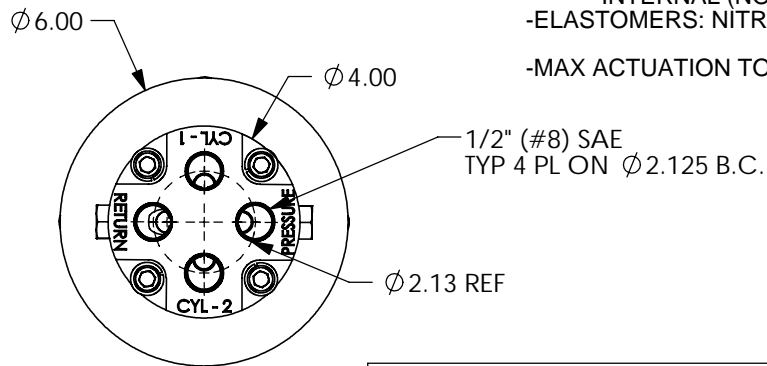
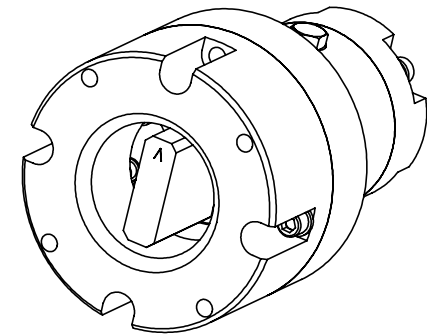

MODEL No. SVS-50-6S1PN

**PacSeal HYDRAULICS INC.**

VALVES, ACCUMULATORS, CONTROLS

PROPRIETARY AND CONFIDENTIAL  
THE INFORMATION CONTAINED IN THIS DRAWING IS THE SOLE  
PROPERTY OF PacSeal Hydraulics.  
ANY REPRODUCTION IN PART OR AS A WHOLE WITHOUT THE  
WRITTEN PERMISSION OF PacSeal Hydraulics IS PROHIBITED.

TITLE  
SVS-50 Selector  
w/ Intervention Fixture

SIZE <b>A</b>	DWG. NO. <b>40-4175</b>	REV <b>1</b>
SCALE: 1:4	Weight: 41.6	SHEET 1 OF 2

Note: Items # 20 belong to 40-4854 Assembly. Shown Exploded for reference.

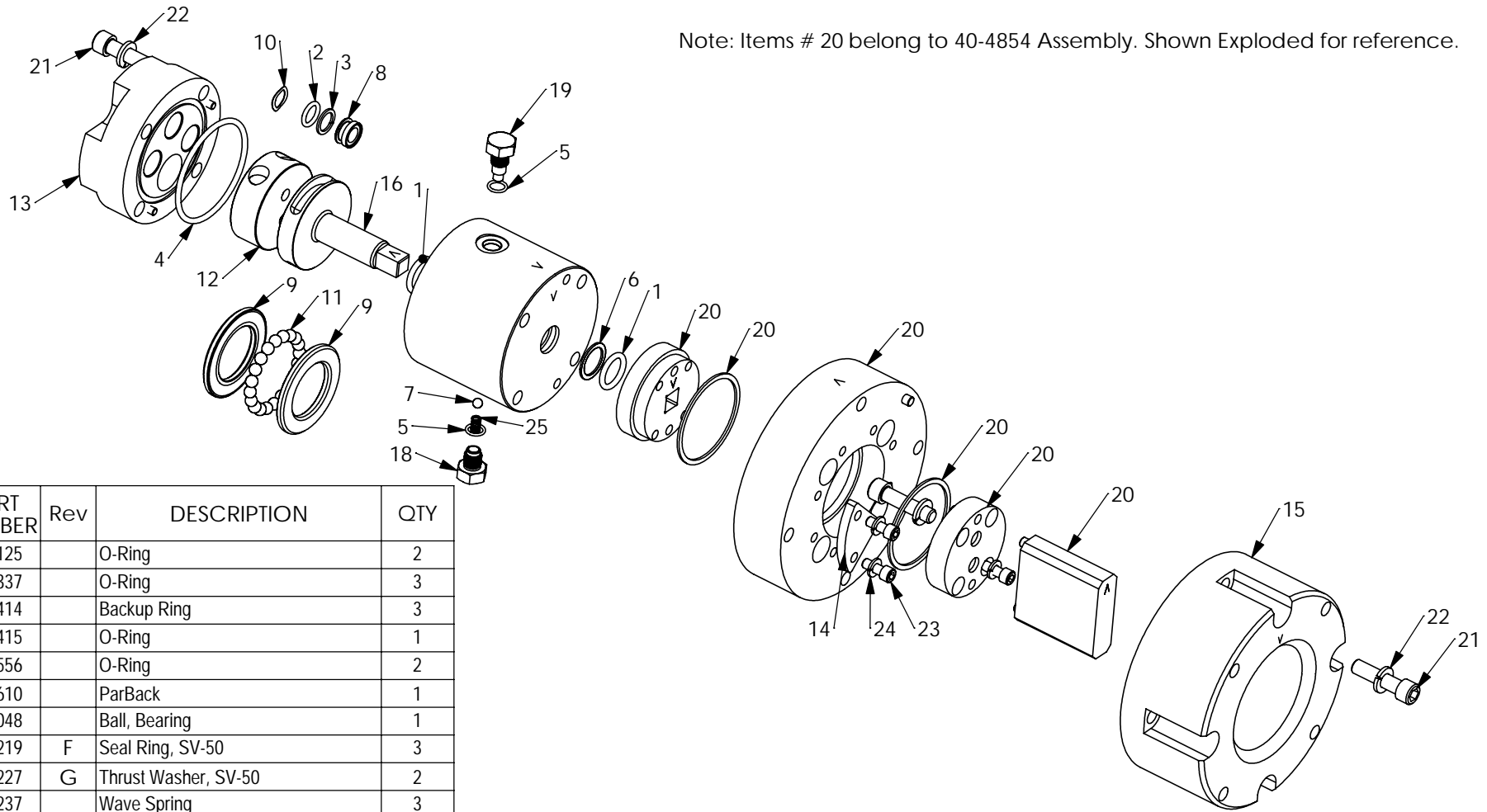

ITEM NO.	PART NUMBER	Rev	DESCRIPTION	QTY
1	23-1125		O-Ring	2
2	23-1337		O-Ring	3
3	23-1414		Backup Ring	3
4	23-1415		O-Ring	1
5	23-1556		O-Ring	2
6	23-1610		ParBack	1
7	40-0048		Ball, Bearing	1
8	40-0219	F	Seal Ring, SV-50	3
9	40-0227	G	Thrust Washer, SV-50	2
10	40-0237		Wave Spring	3
11	40-0259		Ball, Bearing	20
12	40-0262	D	Rotor, SV-50 Selector	1
13	40-2537	B	Body, SVS-50 1/2"SAE Ported	1
14	40-3694	1	Plate, Paddle Stop	2
15	40-3703	1	Collar -Top, Intervention Fixture	1
16	40-4173	1	Shaft, SVS-50	1
17	40-4174	1	Housing, SVS-50	1
18	40-4807	1	Detent Plug, #4 SAE	1
19	40-4808	1	Hard Stop Plug, #4 SAE	1
20	40-4854	1	Actuator Assembly, SVS	1
21	50-0230		Bolt, SHCS	12
22	50-0316		Lock Washer, St Stl	12
23	50-0509		SHCS	4
24	50-0531		Lock Washer	4
25	50-0560		Compression Spring	1

PROPRIETARY AND CONFIDENTIAL  
 THE INFORMATION CONTAINED IN THIS DRAWING IS THE SOLE PROPERTY OF PacSeal Hydraulics. ANY REPRODUCTION IN PART OR AS A WHOLE WITHOUT THE WRITTEN PERMISSION OF PacSeal Hydraulics IS PROHIBITED.

**PACSEAL HYDRAULICS INC.**

VALVES, ACCUMULATORS, CONTROLS

TITLE	SIZE	DWG. NO.	REV
SVS-50 Selector w/ Intervention Fixture	A	40-4175	1
SCALE: 1:4	Est. Wt. 41.6	SHEET 2 OF 2	