



KR-100 Regulator Specifications **Table of Contents**

2. Specifications and Data Sheet
3. Configuration Overview
4. Regulator with Manual Operator Installation Drawing
5. Regulator with Failsafe Air Operator Installation Drawing
6. Regulator with Failsafe Hydraulic Operator Installation Drawing
7. Regulator with Hydraulic Pilot Operator Installation Drawing
8. General Assembly Overview
9. P Model Configurations Assembly Drawing
10. Failsafe Air and Hydraulic Operators Assembly Drawing
11. Tamper Proof Conversion Kit Instructions



All PacSeal Hydraulics' KR Pressure Regulators are designed with ShearFlo® metal-to-metal sealing technology.

ShearFlo® sealing technology features:

- High cycle life and anti-wear design is suitable for critical service applications, including contaminated fluids.
- Leak proof, contaminant resistant metal-to-metal seal is accomplished by lapping and polishing hardened stainless steel sealing elements to exacting standards of finish and flatness.
- The sealing elements are spring preloaded and pressure energized, which maintains contact between the two sealing surfaces at all times.

All KR Regulators are tested to PacSeal's strict quality control standards to ensure proper function and reliability. Every ShearFlo® sealing component in a repair kit is inspected to ensure trouble-free performance after field maintenance and repair.

PacSeal Hydraulics' KR Pressure Regulators serve as pressure reducing and regulating valves to maintain system pressure at a desired value (set pressure) which is below that of the supply pressure.

The operator controls the outlet pressure by modulating the compression of springs that act on a pressurized piston. This in turn balances the hydraulic load inside the body. The operator options are as follows:

- Manual
- Failsafe Air Motor with Manual Override
- Failsafe Hydraulic Motor with Manual Override
- Hydraulic Pilot

General Specifications	
Supply Port Size	1 in. NPT or SAE ORB (2X)
Outlet Port Size	1-1/2 in. NPT or SAE ORB
Vent Port Size	1 in. NPT or SAE ORB
Working Pressure Options (Liquid)	3000 or 5000 psi
Regulated Outlet Pressure Options	See Product Configurator
Cv Factor Outlet	10.3
Cv Factor Vent	1.4
Rated Flow	90 gpm
Temperature Rating (Regulators and Failsafe Air Motors)	-40° to 250°F
Fluid Media	Hydraulic oil or lubricated water ¹
Weight	See installation drawings
Materials	
ShearFlo Sealing Components (i.e. Rotor and Seal Rings)	Hardened stainless steel ¹
Body	Carbon Steel
Flanges and Operators	Carbon Steel
Hardware	Coated Carbon Steel
O-rings	Buna-N (N), Viton (V), or EPR (E)
Backup Rings	Teflon

¹For water based media, special alloy seal rings may be required for optimum performance and durability - Contact PacSeal for details.

Model	Supply Pressure [psi]	Regulated Outlet Pressure [psi]	Deadband Range [psi]*
R	3000/5000	300-2000	100-200
P		50-5000	0-100

*Deadband is the difference between the set pressure and the actual outlet pressure that triggers the KR to open or vent. The deadband will vary depending on factors that influence the friction between the seal rings and flow plates, such as: type of fluid and lubricity properties, temperature, differential pressure between supply and regulated outlet, seal ring and flow plate wear condition, and lastly interpretation influenced by gauge sensitivity. The Reset Range or Hysteresis is within +/- 150 psi for all models.

Model Number Configurator

Basic Model	Ports	Supply Pressure	Regulated Outlet		Operator	Water Glycol App's
			<u>Operating Range²</u>	<u>Deadband</u>		
KR-100	N NPT	3 3000 psi			M Manual	-W ¹ Special Alloy
	S SAE	5 5000 psi	R 300-2000 psi	100-200 psi	FSA Failsafe Air Motor FSH Failsafe Hydraulic Motor	Seal Rings
			P ² 50-5000 psi	0-100 psi	H Hydraulic Pilot	Leave blank if N/A

Notes: ¹ Not a standard option - special order only

² Regulated Outlet Pressure cannot exceed supply pressure. Absolute Outlet Pressure is 0 psi up to 25% above the maximum operating pressure.

³ Maximum regulated outlet pressure matches the supply pressure for a regulator with the Hydraulic Pilot operator

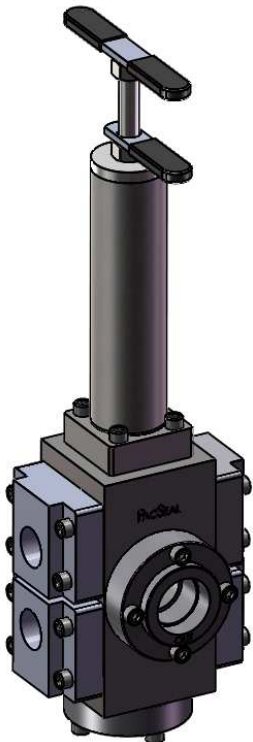

KR-100 Regulator with Standard Ports (NPT/SAE) and Manual Operator
Example: KR-100N3RM

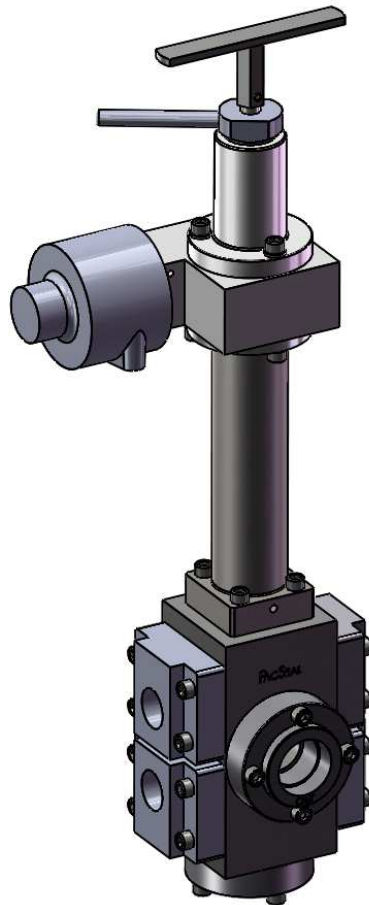

KR-100 Regulator with Failsafe Air Motor Operator
Example: KR-100S3RFSA

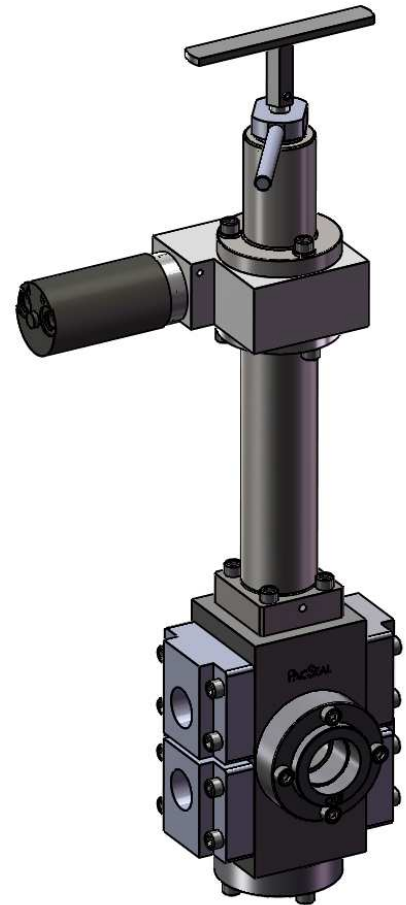

KR-100 Regulator with Failsafe Hydraulic Motor Operator
Example: KR-100N5RFSH

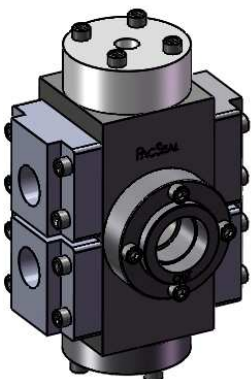

KR-100 Regulator with Hydraulic Pilot Operator
Example: KR-100N5PH



PROPRIETARY AND CONFIDENTIAL
THE INFORMATION CONTAINED IN THIS DRAWING IS THE SOLE PROPERTY OF PacSeal. ANY REPRODUCTION IN PART OR AS A WHOLE WITHOUT THE WRITTEN PERMISSION OF PacSeal IS PROHIBITED.

TITLE
Configuration Overview

SIZE A	REV 7
SHEET 3 OF 11	

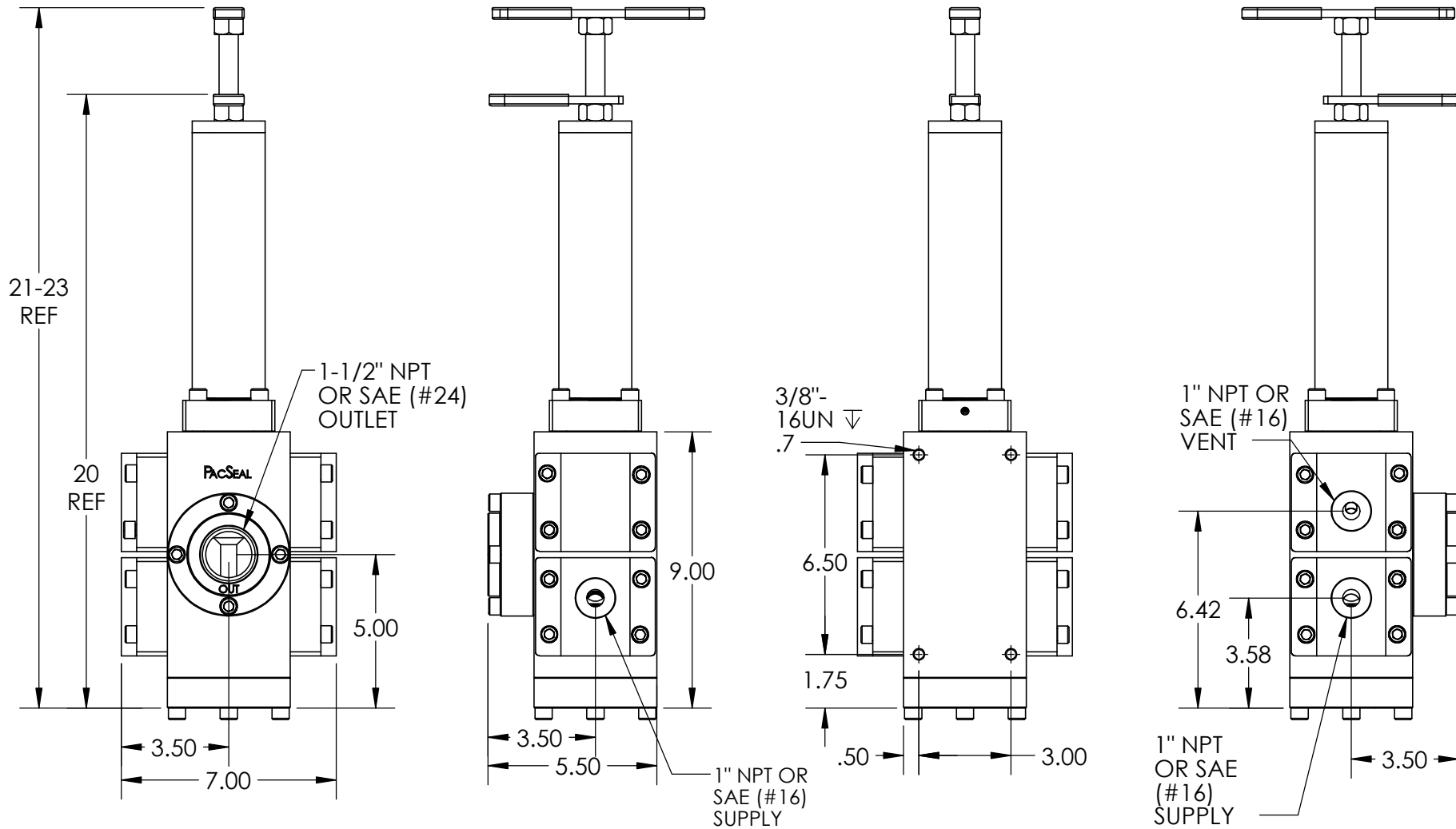

Notes:

1. Adjustment handle can be threaded in or out to increase or decrease compression on the spring and thus on the regulated outlet pressure.
2. Model configuration (Regulated Outlet Pressure) option: R
3. Weight - 68 lb.
4. All dimensions are consistent for KR-100 NPT or SAE ORB porting options, regardless of supply/outlet pressure and operator selection.

			
<p>PROPRIETARY AND CONFIDENTIAL</p> <p>THE INFORMATION CONTAINED IN THIS DRAWING IS THE SOLE PROPERTY OF PacSeal. ANY REPRODUCTION IN PART OR AS A WHOLE WITHOUT THE WRITTEN PERMISSION OF PacSeal Hydraulics IS PROHIBITED.</p>	<p>TITLE KR-100 Regulator w/ Manual Operator (NPT/SAE) Installation Drawing</p>	<p>SIZE A</p>	<p>REV 7</p>
			<p>SHEET 4 OF 11</p>

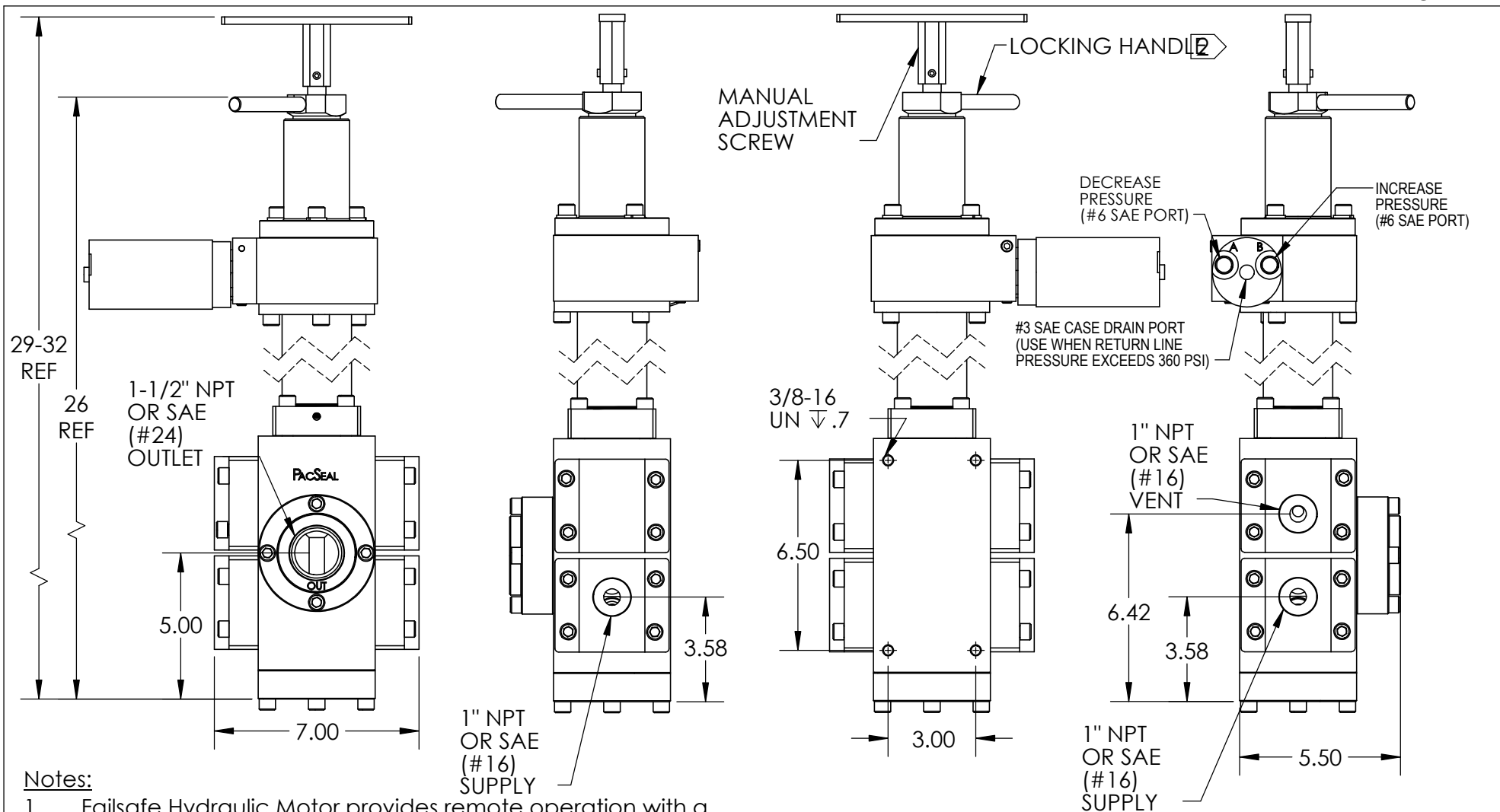

Notes:

1. Failsafe Hydraulic Motor provides remote operation with a manual override. Upon loss of pilot signal, there is no loss of regulated outlet pressure.
- ② Turn locking handle clockwise to lock for failsafe operation. Turn locking handle counter-clockwise to unlock for manual operation/override.
3. Max Hydraulic Motor Supply Pressure - 1500 psi
4. Model configuration (Regulated Outlet Pressure) option: R
5. Weight - 93 lb.
6. All dimensions are consistent for KR-100 NPT or SAE ORB porting options, regardless of supply/outlet pressure and operator selection.

<p style="text-align: center;">PROPRIETARY AND CONFIDENTIAL</p> <p>THE INFORMATION CONTAINED IN THIS DRAWING IS THE SOLE PROPERTY OF PacSeal. ANY REPRODUCTION IN PART OR AS A WHOLE WITHOUT THE WRITTEN PERMISSION OF PacSeal Hydraulics IS PROHIBITED.</p>	<p>TITLE Regulator w/ Failsafe Hydraulic Operator (NPT/SAE) Installation Drawing</p>				
<table border="1" style="width: 100%; border-collapse: collapse;"> <tr> <td style="width: 50%; text-align: center;"> <p>SIZE A</p> </td> <td style="width: 50%; text-align: center;"> <p>REV 7</p> </td> </tr> <tr> <td colspan="2" style="text-align: center;"> <p>SHEET 6 OF 11</p> </td> </tr> </table>		<p>SIZE A</p>	<p>REV 7</p>	<p>SHEET 6 OF 11</p>	
<p>SIZE A</p>	<p>REV 7</p>				
<p>SHEET 6 OF 11</p>					

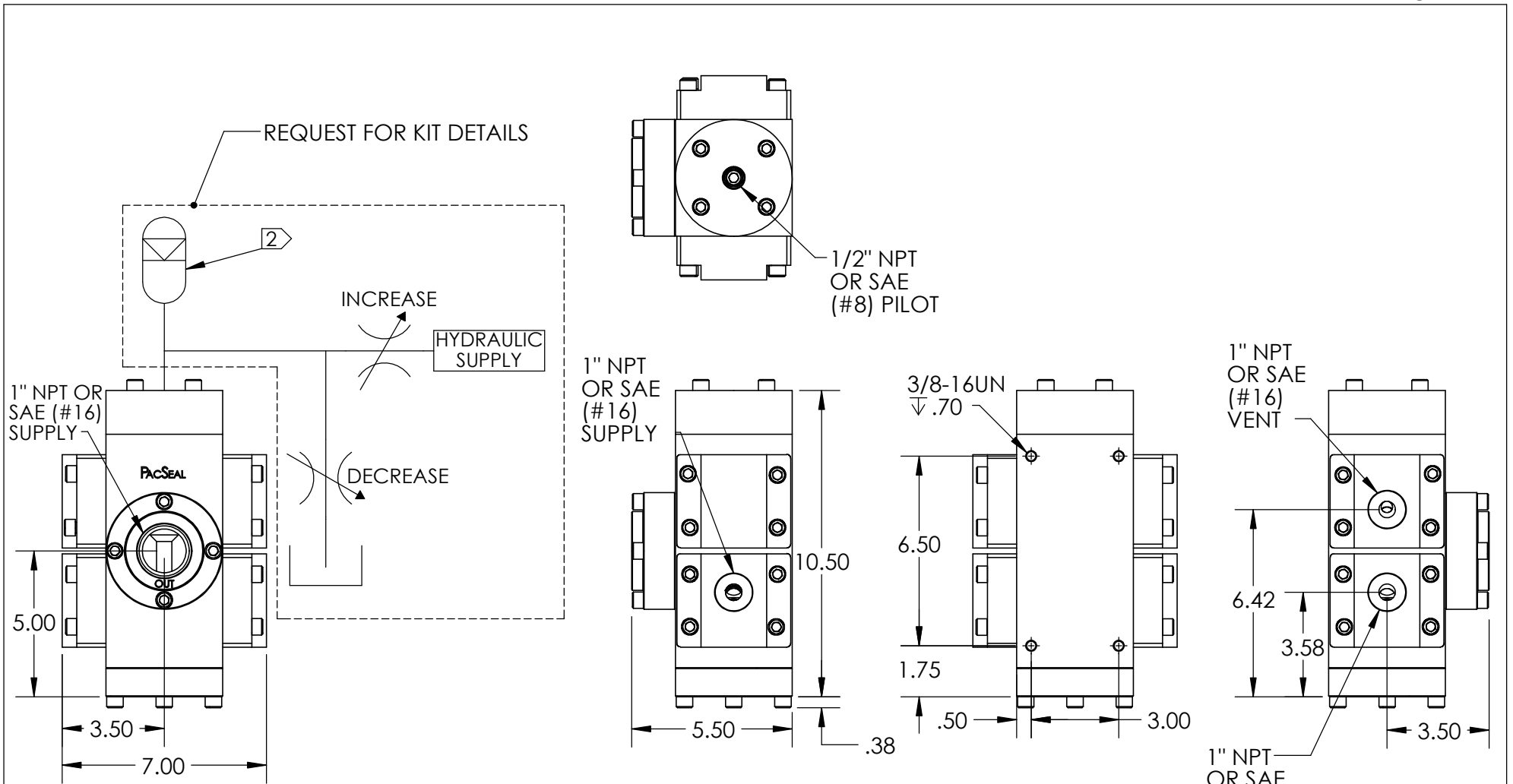

Notes:

1. A remote, variable hydraulic signal operates on a piston with a 1:1 ratio which allows for the most precisely controlled outlet pressures of all options. Loss of hydraulic pilot pressure will result in the outlet venting to tank.
- ② Minimum 1 Pint Accumulator is recommended for operation
3. Model configuration (Regulated Outlet Pressure) option: P
4. Weight - 58 lb.
5. All dimensions are consistent for KR-100 NPT or SAE ORB porting options, regardless of supply/outlet pressure and operator selection.



PROPRIETARY AND CONFIDENTIAL
 THE INFORMATION CONTAINED IN THIS DRAWING IS THE SOLE PROPERTY OF PacSeal. ANY REPRODUCTION IN PART OR AS A WHOLE WITHOUT THE WRITTEN PERMISSION OF PacSeal IS PROHIBITED.

**TITLE KR-100 Regulator w/
 Hydraulic Pilot
 Operator (NPT/SAE)
 Installation Drawing**

SIZE A	REV 7
SHEET 7 OF 11	

Notes:

1. Hydraulic Pilot model configuration shown in sheet 9.
2. Failsafe motor operator assembly drawings shown in sheet 10.
3. Contact PacSeal for replacement parts.
4. Refer to *KR-100 Maintenance Instructions* for more details.

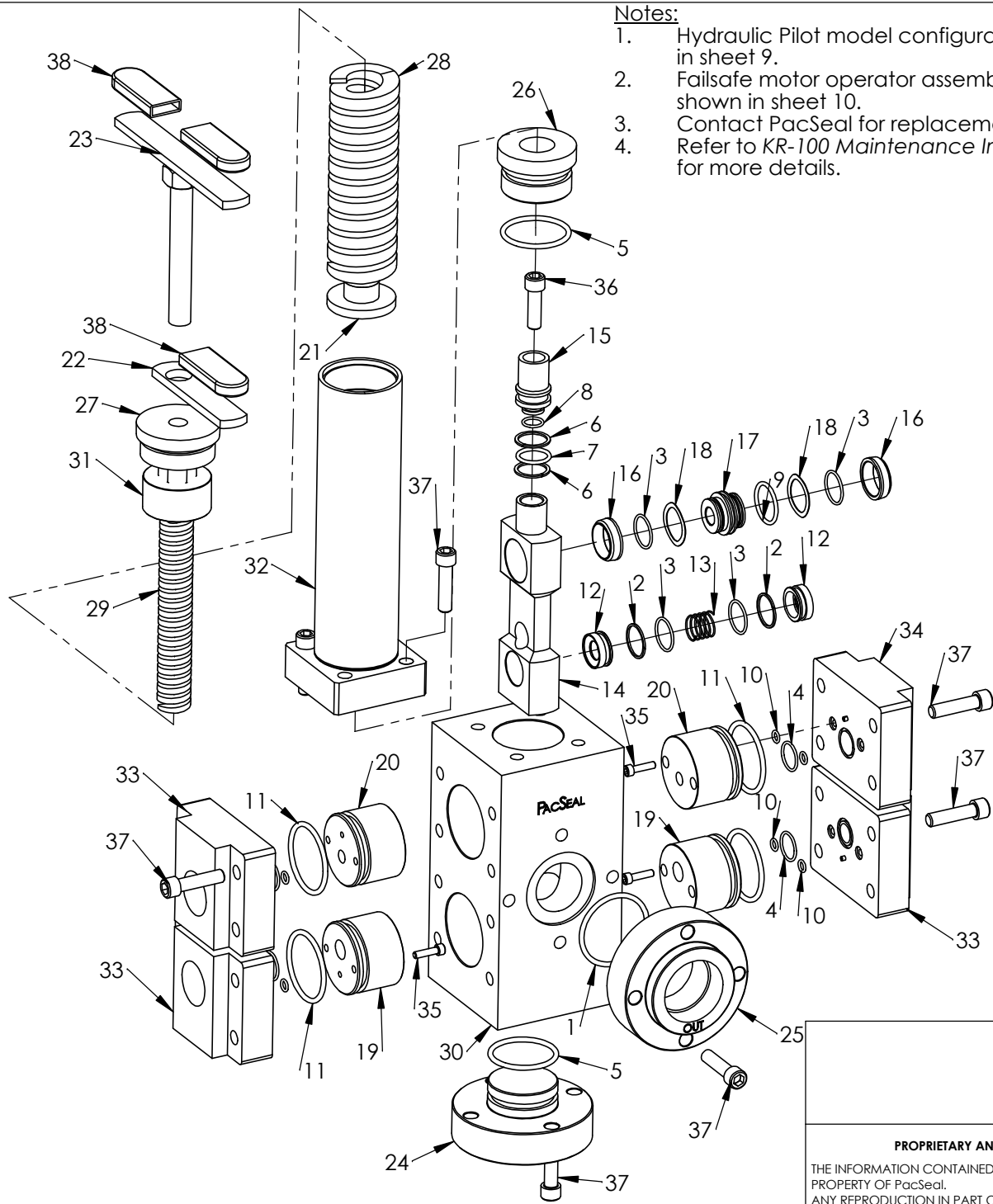

ITEM NO.	PART NUMBER	DESCRIPTION	QTY.
1	23-1126	O-Ring	1
2	23-1322	Backup Ring	2
3	23-1323	O-Ring	4
4	23-1326	O-Ring	4
5	23-1330	O-Ring	2
6	23-1331	Backup Ring	2
7	23-1332	O-Ring	1
8	23-1333	O-Ring	1
9	23-1334	O-Ring	1
10	23-1335	O-Ring	8
11	23-1336	O-Ring	4
12	40-0014	Seal Ring,	2
13	40-0110	Spring	1
14	40-0111	Seal Container, KR-100	1
15	40-0112	Piston, KR-100M	1
16	40-0113	Seal Ring- Vent	2
17	40-0114	Valve Cage	1
18	40-0115	Wave Spring	2
19	40-0117	Flow Plate, Supply KR-100	2
20	40-0118	Flow Plate, Vent KR-100	2
21	40-0134	Spring Plate	1
22	40-0135	Lock Handle	1
23	40-0136	Adjusting Screw & Handle	1
24	40-0137	Flange, Lower	1
③	25	Note 3 Flange, Outlet	1
26	40-0139	Guide Plunger	1
27	40-0140	Plug, Adjustment Head	1
28	40-0143	Spring, Outer	1
29	40-0144	Spring, Inner	1
30	40-0148	Body, KR-100	1
31	40-0300	Spring Guide	1
32	40-0388	Adjustment Head	1
③	33	Note 3 Flange, Inlet & Vent	3
34	40-0959	Flange, Blind	1
35	50-0067	Bolt, SHCS	8
36	50-0068	Bolt, SHCS	1
37	50-0069	Bolt, SHCS	28
38	50-0239	Grip, Handle	3



PROPRIETARY AND CONFIDENTIAL
 THE INFORMATION CONTAINED IN THIS DRAWING IS THE SOLE PROPERTY OF PacSeal. ANY REPRODUCTION IN PART OR AS A WHOLE WITHOUT THE WRITTEN PERMISSION OF PacSeal Hydraulics IS PROHIBITED.

TITLE
General Assembly Overview

SIZE A	REV 7
SHEET 8 OF 11	

Notes:

- The listed components vary based on Regulated Outlet Pressure, while all other regulator components (shown in sheet 8 "General Assembly Overview") are shared.

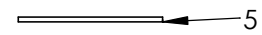
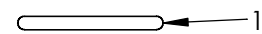
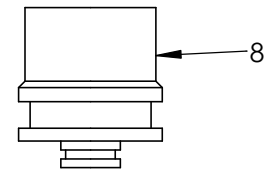
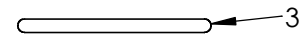
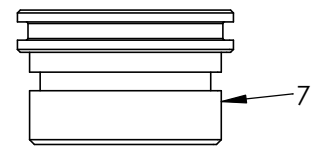
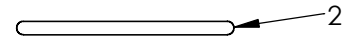
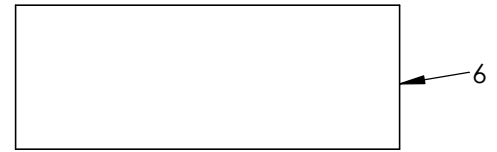
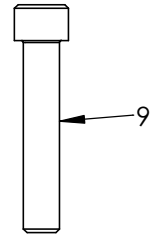

Model	Supply Pressure (psi)	Regulated Outlet Pressure (psi)	Deadband (psi)
P	3000/5000	50-5000	0-100

ITEM NO.	PART NUMBER	DESCRIPTION	QTY.
1	23-1124	O-Ring	1
2	23-1126	O-Ring	1
3	23-1330	O-Ring	1
4	23-1333	O-Ring	1
5	23-1342	Backup Ring	2
6	40-0304	Hydraulic Head	1
7	40-0315	Piston Guide, R	1
8	40-2713	Piston, R	1
9	50-0080	Bolt	1

**KR-100 P Regulator
(Hydraulic Pilot)**



PROPRIETARY AND CONFIDENTIAL
 THE INFORMATION CONTAINED IN THIS DRAWING IS THE SOLE PROPERTY OF PacSeal.
 ANY REPRODUCTION IN PART OR AS A WHOLE WITHOUT THE WRITTEN PERMISSION OF PacSeal IS PROHIBITED.

TITLE **P Model Configuration Assembly Drawing**

SIZE A	REV 7
SHEET 9 OF 11	

ITEM NO.	PART NUMBER	DESCRIPTION	QTY.
1	23-1123	O-Ring	1
2	23-1356	O-Ring	1
3	23-1385	O-Ring	1
4	23-1404	O-Ring	1
5	23-1405	O-Ring	1
6	40-0414	Adapter Plate	1
7	40-0416	Failsafe Collar	1
8	40-0418	Failsafe Handle	1
9	40-0419	Shaft Extension, Failsafe Air	1
10	40-0543	Motor, Failsafe Air Standard	1
11	40-2742	Worm	1
12	40-3960	Fail Safe Shaft, KR	1
13	40-3962	Housing, KR Shaft Adjustment	1
14	40-3964	Failsafe Nut Assy	1
15	40-4978	Failsafe Body	1
16	40-4979	Worm Gear	1
17	50-0072	Screw	6
18	50-0103	Lock Washer	3
19	50-0154	Roll Pin	1
20	50-0156	Screw	1
21	50-0157B	Bearing, NTA-1220	1
22	50-0157T	Thrust Washer, TRB-1220	2
23	50-0158	Roller Bearing	1
24	50-0160	Set Screw	2
25	50-0223	Set Screw	2
26	50-0287	Roll Pin	1
27	50-0483	Roller Bearing	1
28	50-0686	Bearing	1
29	50-0687	Thrust Washer	2

Failsafe Air Operator (40-3963)

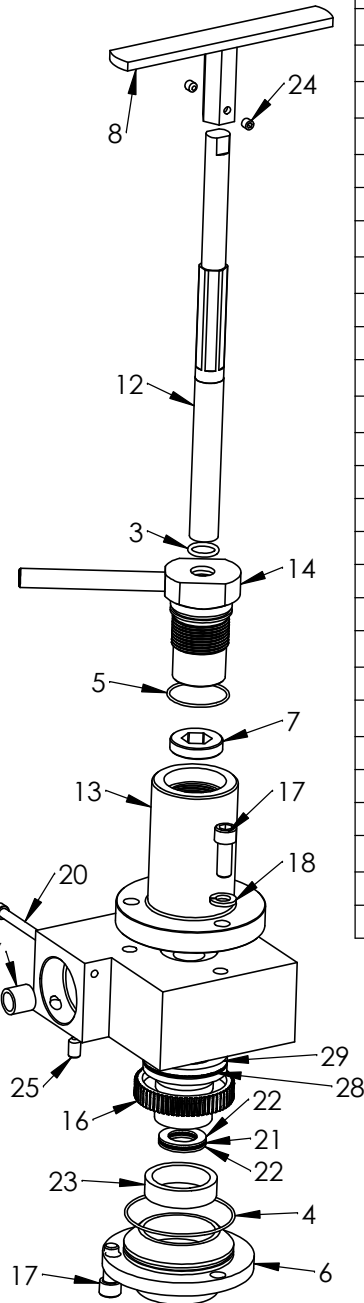

ITEM NO.	PART NUMBER	DESCRIPTION	QTY.
1	23-1123	O-Ring	1
2	23-1356	O-Ring	1
3	23-1385	O-Ring	1
4	23-1404	O-Ring	1
5	23-1405	O-Ring	1
6	40-0414	Adapter Plate	1
7	40-0416	Failsafe Collar	1
8	40-0418	Failsafe Handle	1
9	40-0715	Hydraulic Adapter	1
10	40-0719	Motor, Failsafe Hydraulic	1
11	40-2742	Worm	1
12	40-3960	Failsafe Shaft	1
13	40-3962	Housing, KR Shaft Adjustment	1
14	40-3964	Failsafe Nut Assy	1
15	40-4978	Failsafe Body	1
16	40-4979	Worm Gear	1
17	50-0072	Screw	6
18	50-0103	Lock Washer	3
19	50-0154	Roll Pin	1
20	50-0156	Screw	1
21	50-0157B	Bearing	1
22	50-0157T	Thrust Washer	2
23	50-0158	Roller Bearing	1
24	50-0160	Set Screw	2
25	50-0215	Screw	4
26	50-0223	Set Screw	2
27	50-0483	Roller Bearing	1
28	50-0686	Thrust Bearing, NTA-2435	1
29	50-0687	Thrust Washer, TRF-2435	2

Failsafe Hydraulic Operator (40-4255)

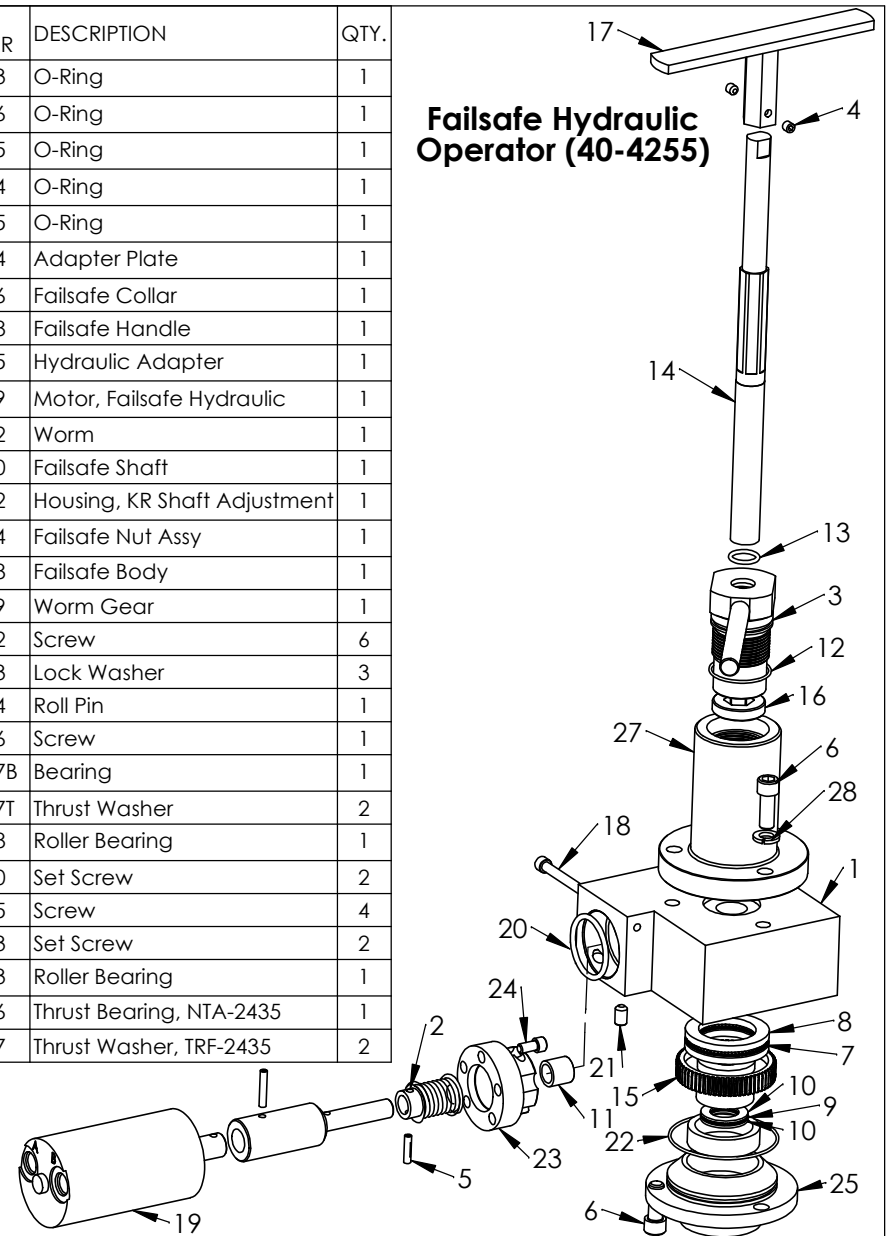

PROPRIETARY AND CONFIDENTIAL
 THE INFORMATION CONTAINED IN THIS DRAWING IS THE SOLE PROPERTY OF PacSeal. ANY REPRODUCTION IN PART OR AS A WHOLE WITHOUT THE WRITTEN PERMISSION OF PacSeal IS PROHIBITED.

TITLE **Failsafe Air and Hydraulic Operators Assembly Drawing**

SIZE A	REV 7
SHEET 10 OF 11	

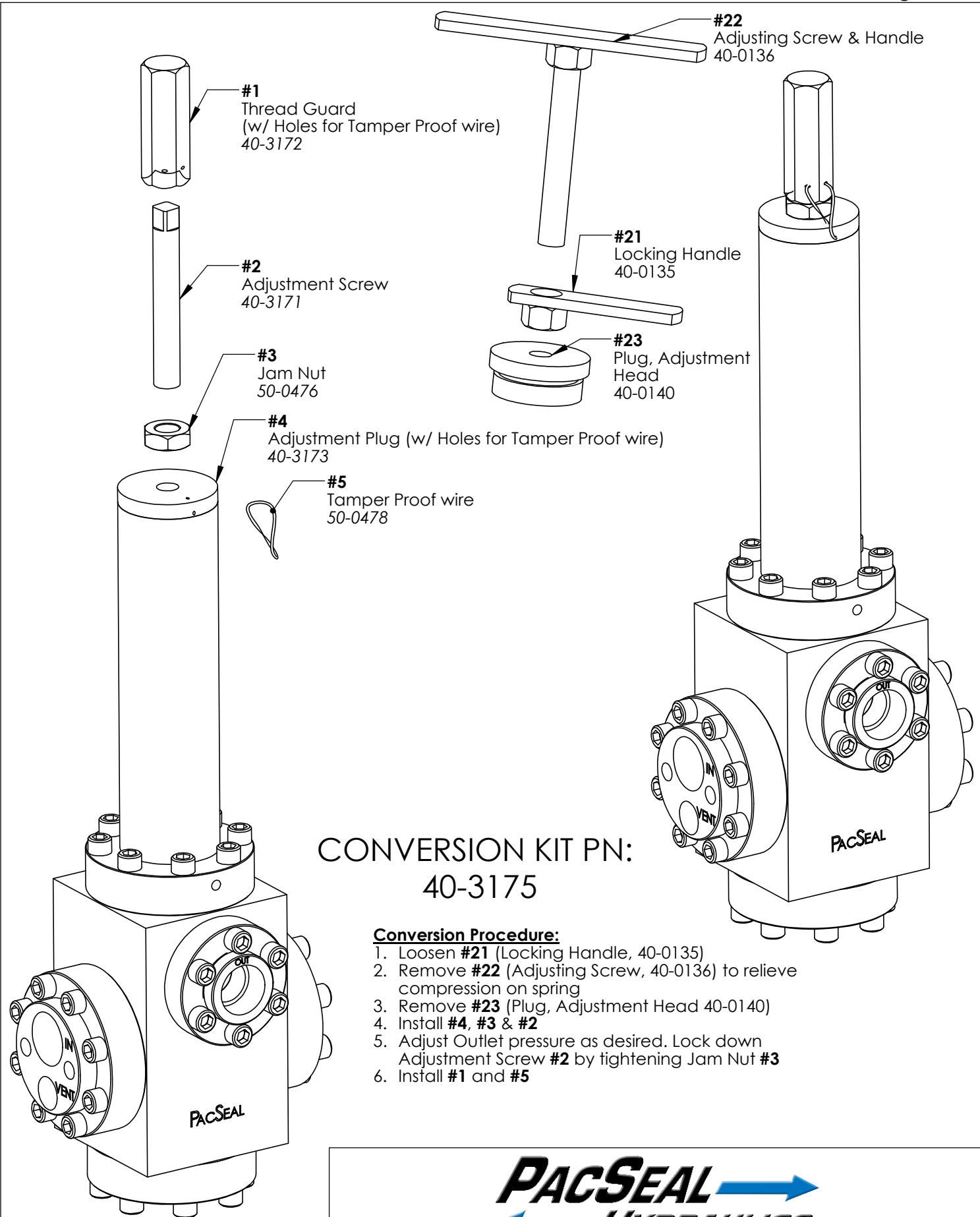

**CONVERSION KIT PN:
40-3175**

Conversion Procedure:

1. Loosen **#21** (Locking Handle, 40-0135)
2. Remove **#22** (Adjusting Screw, 40-0136) to relieve compression on spring
3. Remove **#23** (Plug, Adjustment Head 40-0140)
4. Install **#4**, **#3** & **#2**
5. Adjust Outlet pressure as desired. Lock down Adjustment Screw **#2** by tightening Jam Nut **#3**
6. Install **#1** and **#5**



PROPRIETARY AND CONFIDENTIAL
THE INFORMATION CONTAINED IN THIS DRAWING IS THE SOLE PROPERTY OF PacSeal.
ANY REPRODUCTION IN PART OR AS A WHOLE WITHOUT THE WRITTEN PERMISSION OF PacSeal IS PROHIBITED.

TITLE
Tamper Proof Conversion Kit

SIZE A	REV 1
SHEET 11 OF 11	