



## *KR-140 Regulator Specifications* **Table of Contents**

2. Specifications and Data Sheet
3. Configuration Overview
4. Regulator with Manual Operator Installation Drawing
5. Regulator with Failsafe Air Operator Installation Drawing
6. Regulator with Failsafe Hydraulic Operator Installation Drawing
7. Regulator with Hydraulic Pilot Operator Installation Drawing
8. Subplate Mount Regulator Installation Drawing
9. High Pressure Output Regulator with Manual Operator Installation Drawing
10. High Pressure Output Regulator with High Torque Failsafe Air Operator Installation Drawing
11. High Pressure Output Regulator with Failsafe Hydraulic Operator Installation Drawing
12. Internal Override Bypass Options Installation Drawing
13. General Assembly Overview
14. L and H Model Configurations Assembly Drawing
15. R and V Model Configurations Assembly Drawing
16. D and W Model Configurations Assembly Drawing
17. P Model Configuration Assembly Drawing
18. Failsafe Air and Hydraulic Operators Assembly Drawing
19. High Pressure Output Adjustment Head Assembly Drawing
20. High Pressure Output Failsafe Manual Assembly Drawing
21. High Pressure Output Failsafe Air Operator Assembly Drawing
22. High Pressure Output Failsafe Hydraulic Operator Assembly Drawing
23. Internal Override Bypass Direct Operation Assembly Drawing
24. Internal Override Bypass with SV-25 Assembly Drawing
25. Internal Override Bypass with SVx-25 Assembly Drawing
26. Tamper Proof Conversion Kit Instructions



All PacSeal Hydraulics' KR Pressure Regulators are designed with ShearFlo® metal-to-metal sealing technology.

ShearFlo® sealing technology features:

- High cycle life and anti-wear design is suitable for critical service applications, including contaminated fluids.
- Leak proof, contaminant resistant metal-to-metal seal is accomplished by lapping and polishing hardened stainless steel sealing elements to exacting standards of finish and flatness.
- The sealing elements are spring preloaded and pressure energized, which maintains contact between the two sealing surfaces at all times.

All KR Regulators are tested to PacSeal's strict quality control standards to ensure proper function and reliability. Every ShearFlo® sealing component in a repair kit is inspected to ensure trouble-free performance after field maintenance and repair.

PacSeal Hydraulics' KR Pressure Regulators serve as pressure reducing and regulating valves to maintain system pressure at a desired value (set pressure) which is below that of the supply pressure.

The operator controls the outlet pressure by modulating the compression of springs that act on a pressurized piston. This in turn balances the hydraulic load inside the body. The operator options are as follows:

- Manual
- Failsafe Air Motor with Manual Override
- Failsafe Hydraulic Motor with Manual Override
- Hydraulic Pilot

The internal override bypass operator provides a lean solution for tight space applications by allowing full accumulator pressure to be supplied downstream of the regulator without a dedicated 4-way bypass valve in the hydraulic circuit.

General Specifications	
Supply Port Size	1 in. NPT or SAE ORB (2X)
Outlet Port Size	1-1/2 in. NPT or SAE ORB
Vent Port Size	1/2 in. NPT or SAE ORB
Working Pressure Options (Liquid)	3000, 5000 or 6000 psi
Regulated Outlet Pressure Options	See Product Configurator
Cv Factor Outlet	23
Cv Factor Vent	2.8
Rated Flow	200 gpm
Temperature Rating (Regulators and Failsafe Air Motors)	-40° to 250°F
Fluid Media	Hydraulic oil or lubricated water <sup>1</sup>
Weight	See installation drawings
Materials	
ShearFlo Sealing Components (i.e. Rotor and Seal Rings)	Hardened stainless steel <sup>1</sup>
Body	Stainless Steel
Operators	Carbon Steel
Flanges and Hardware	Coated Carbon Steel
O-rings	Buna-N (N), Viton (V), or EPR (E)
Backup Rings	Teflon

<sup>1</sup>For water based media, special alloy seal rings may be required for optimum performance and durability - Contact PacSeal for details.

Model	Supply Pressure [psi]	Regulated Outlet Pressure [psi]	Deadband Range [psi]*
L	3000/5000	200-2000	85-150
R	3000/5000	550-2500	300-600
H	5000/6000	350-3300	85-150
D	5000/6000	400-4000	150-250
V	6000	1200-5500	450-800
W	6000	600-5000	150-250
P	3000/5000/6000	50-6000	0-100

\*Deadband is the difference between the set pressure and the actual outlet pressure that triggers the KR to open or vent. The deadband will vary depending on factors that influence the friction between the seal rings and flow plates, such as: type of fluid and lubricity properties, temperature, differential pressure between supply and regulated outlet, seal ring and flow plate wear condition, and lastly interpretation influenced by gauge sensitivity. The Reset Range or Hysteresis is within +/- 150 psi for all models.

## Model Number Configurator

Basic Model	Ports	Supply Pressure	Regulated Outlet Pressure		Operator	Internal Override Bypass	Water Glycol App's
			Operating Range <sup>2</sup>	Deadband			
N	NPT	3 3000 psi	L 200-2000 psi	85-150 psi	M Manual	-IO Direct	-W <sup>1</sup> Special Alloy
S	SAE	5 5000 psi	R 550-2500 psi	300-600 psi	FSA Failsafe Air Motor	-IS with SV-25	Seal Rings
M	Subplate Mount (NPT) <sup>1</sup>	5 5000 psi	H 350-3300 psi	85-150 psi	FSH Failsafe Hydraulic	-IX with SVx-25	
KR-140 T	Subplate Mount (SAE) <sup>1</sup>	6 6000 psi	D 400-4000 psi	150-250 psi			
C	Code-61 <sup>1</sup>	6 6000 psi	W 600-5000 psi	150-250 psi			
D	Code-62 <sup>1</sup>		V 1200-5500 psi	450-800 psi			
		3, 5, or 6	P <sup>3</sup> 50-6000 psi	0-100 psi	H Hydraulic Pilot		Leave blank if N/A

Notes: <sup>1</sup> Not a standard option - special order only.

<sup>2</sup> Regulated Outlet Pressure cannot exceed supply pressure. Absolute Outlet Pressure is 0 psi up to 25% above the maximum operating pressure.

<sup>3</sup> Maximum regulated outlet pressure matches the supply pressure for a regulator with the Hydraulic Pilot operator.

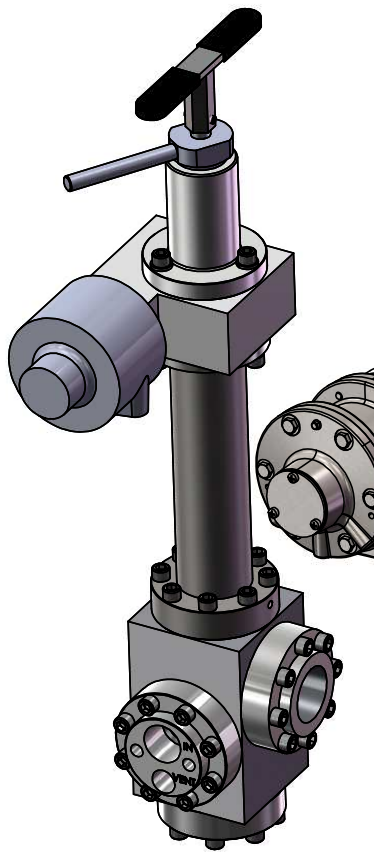

**KR-140 Regulator with Standard Ports (NPT/SAE) and Manual Operator**  
Example: KR-140N3LFSA

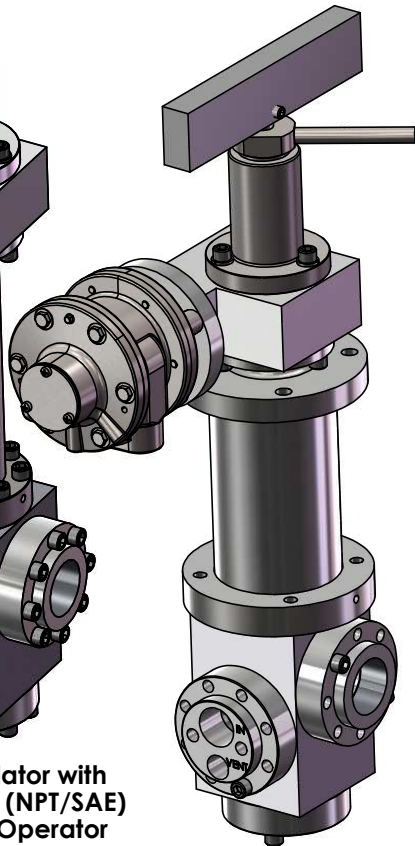

**KR-140 Regulator with High Pressure Low Deadband and Failsafe Air Motor Operator**  
Example: KR-140N5HFSA

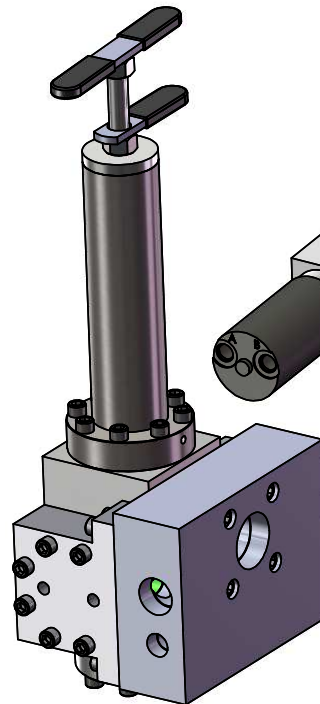

**KR-140 Regulator with Subplate Mount (NPT/SAE) and Manual Operator**  
Example: KR-140M6VM

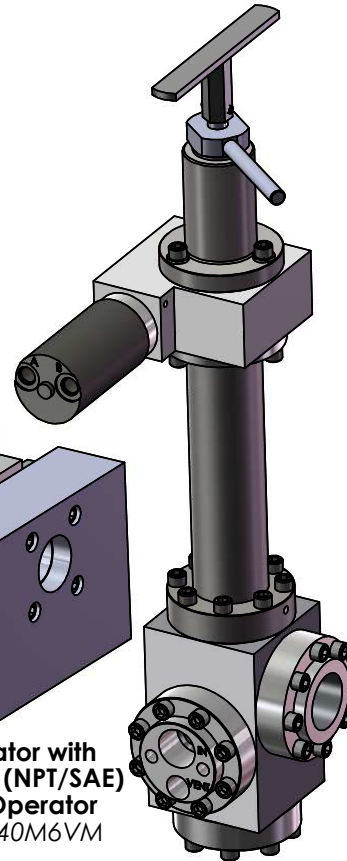

**KR-140 Regulator with Failsafe Hydraulic Motor Operator**  
Example: KR-140S3RFSH

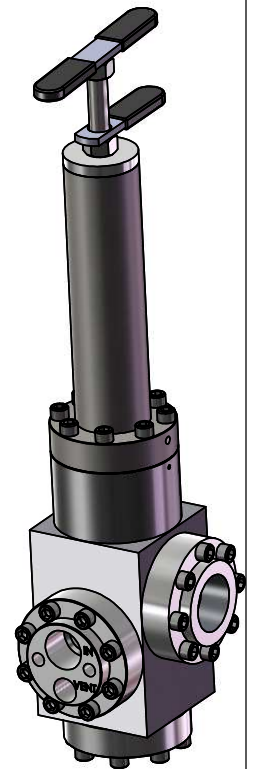

**KR-140 Regulator with Direct Internal Override**  
Example: KR-140N3LM-IO

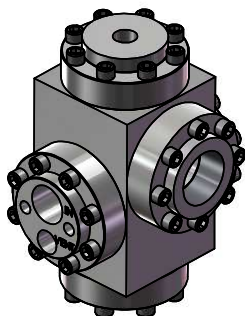

**KR-140 Regulator with Hydraulic Pilot Operator**  
Example: KR-140N6PH



PROPRIETARY AND CONFIDENTIAL

THE INFORMATION CONTAINED IN THIS DRAWING IS THE SOLE PROPERTY OF PacSeal. ANY REPRODUCTION IN PART OR AS A WHOLE WITHOUT THE WRITTEN PERMISSION OF PacSeal IS PROHIBITED.

TITLE

**Configuration Overview**

SIZE

**A**

REV

**7**

SHEET 3 OF 26

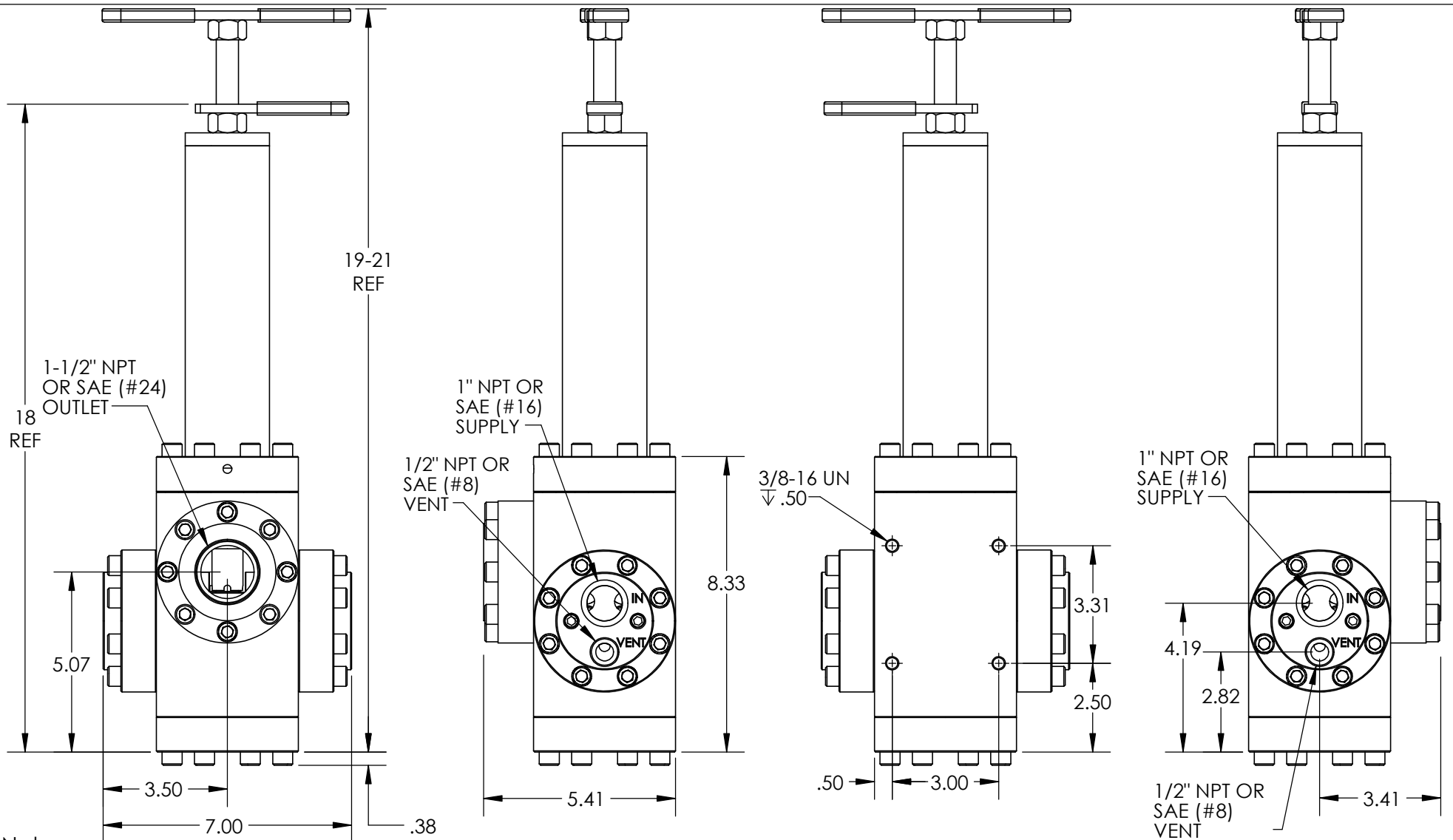

Notes:

1. Adjustment handle can be threaded in or out to increase or decrease compression on the spring and thus on the regulated outlet pressure.
2. Model configuration (Regulated Outlet Pressure) options: D, L, R, V
3. Weight - 50 lb.
4. All dimensions are consistent for KR-140 NPT or SAE ORB porting options, regardless of supply/outlet pressure and operator selection.



**PROPRIETARY AND CONFIDENTIAL**  
 THE INFORMATION CONTAINED IN THIS DRAWING IS THE SOLE PROPERTY OF PacSeal. ANY REPRODUCTION IN PART OR AS A WHOLE WITHOUT THE WRITTEN PERMISSION OF PacSeal Hydraulics IS PROHIBITED.

TITLE  
**KR-140 Regulator w/  
 Manual Operator (NPT/SAE)  
 Installation Drawing**

SIZE <b>A</b>	REV <b>7</b>
SHEET 4 OF 26	

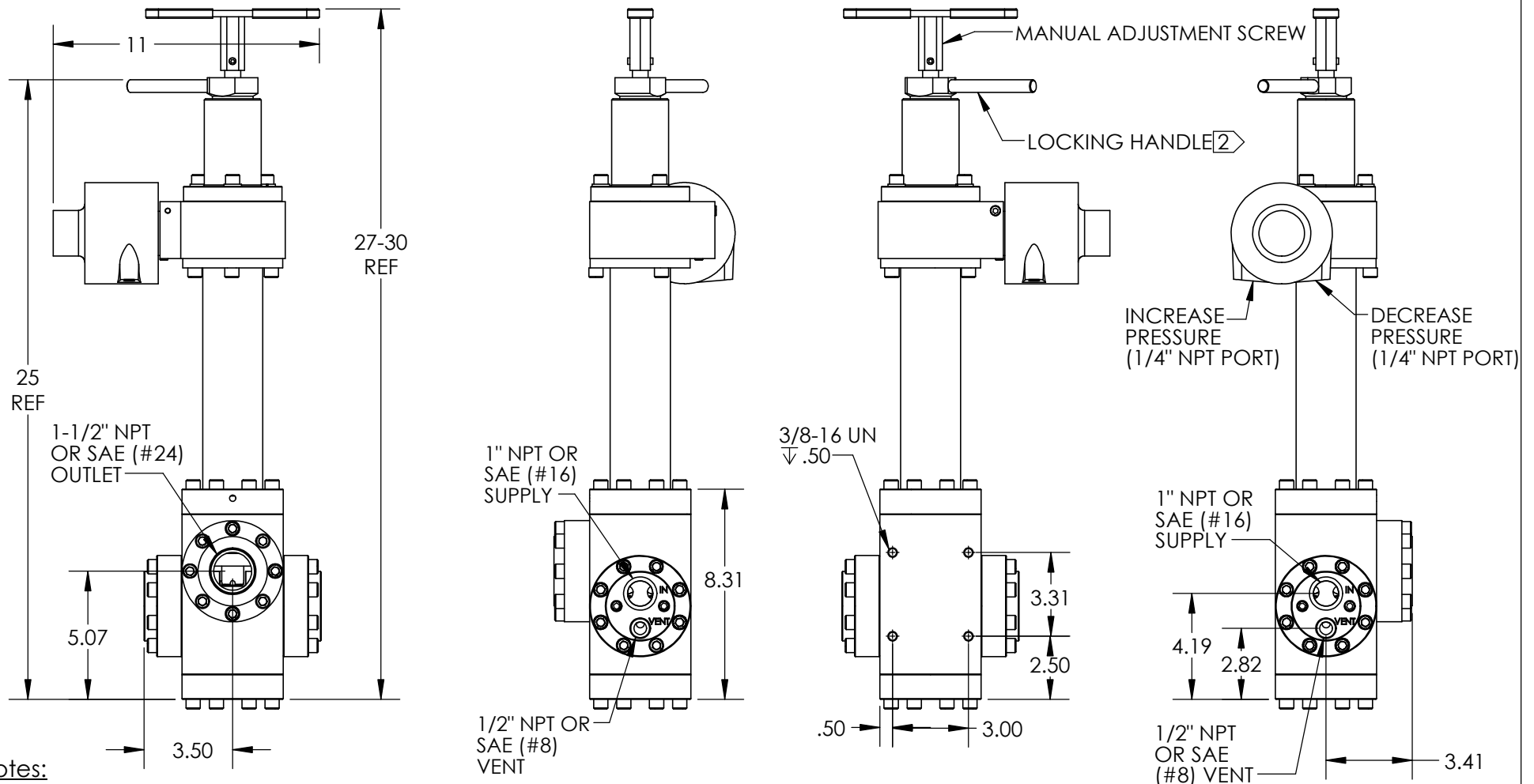

**Notes:**

1. Failsafe Air Motor provides remote operation with a manual override. Upon loss of pilot signal, there is no loss of regulated outlet pressure.
- 2 Turn locking handle clockwise to lock for failsafe remote operation. Turn locking handle counter-clockwise to unlock for manual operation/override.
3. Recommended Air Supply - 115 psi max. with 1/2" tubing
4. Model configuration (Regulated Outlet Pressure) options: D, L, R, V
5. Weight - 79 lb.
6. All dimensions are consistent for KR-140 NPT or SAE ORB porting options, regardless of supply/outlet pressure and operator selection.



**PROPRIETARY AND CONFIDENTIAL**  
 THE INFORMATION CONTAINED IN THIS DRAWING IS THE SOLE PROPERTY OF PacSeal. ANY REPRODUCTION IN PART OR AS A WHOLE WITHOUT THE WRITTEN PERMISSION OF PacSeal Hydraulics IS PROHIBITED.

**TITLE**  
 Regulator w/ Failsafe Air Operator (NPT/SAE) Installation Drawing

SIZE <b>A</b>	REV <b>7</b>
SHEET 5 OF 26	

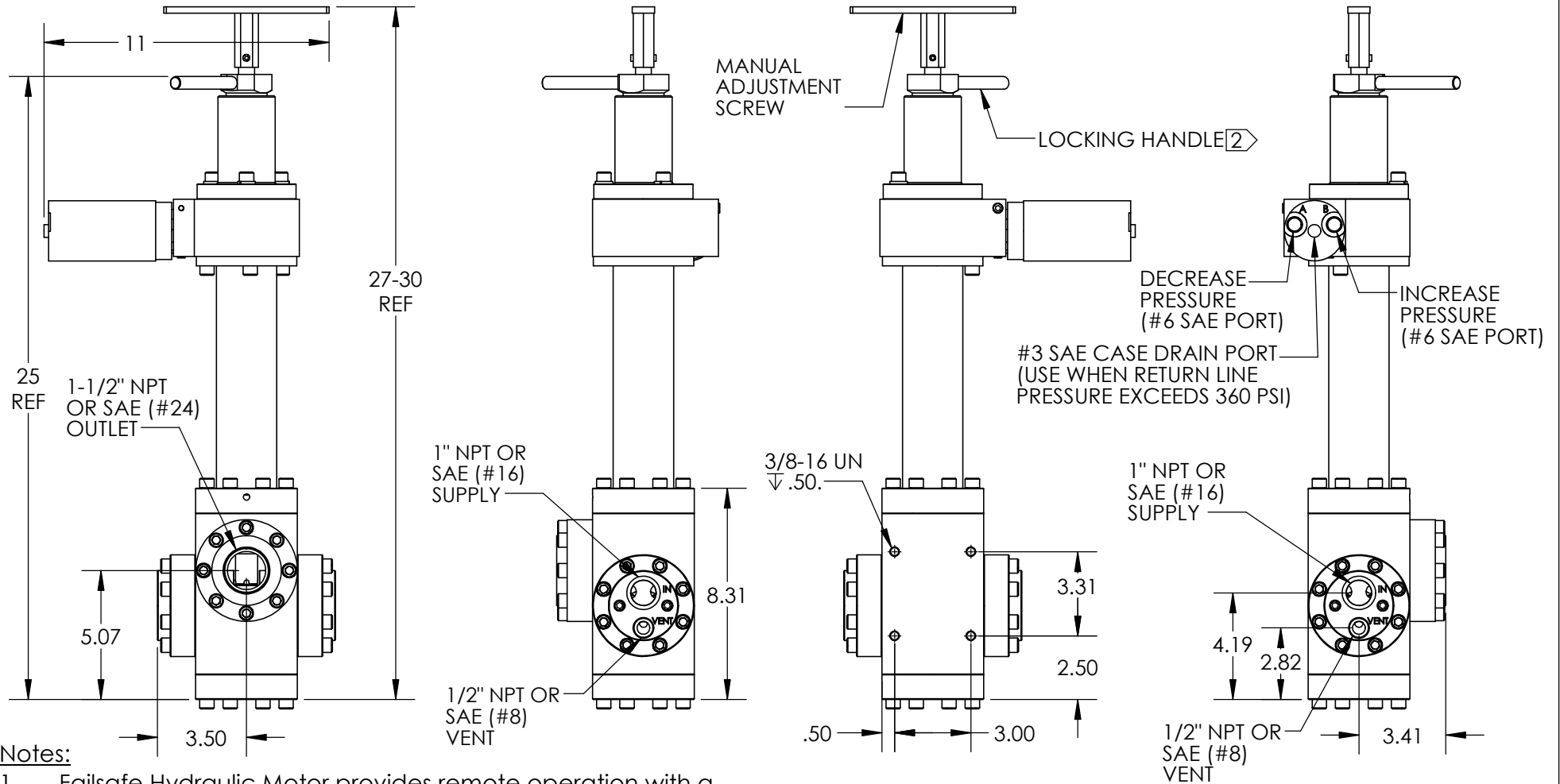

**Notes:**

1. Failsafe Hydraulic Motor provides remote operation with a manual override. Upon loss of pilot signal, there is no loss of regulated outlet pressure.
- ② Turn locking handle clockwise to lock for failsafe remote operation. Turn locking handle counter-clockwise to unlock for manual operation/override.
3. Max Hydraulic Motor Supply Pressure - 1500 psi
4. Model configuration (Regulated Outlet Pressure) options: D, L, R, V
5. Weight - 75 lb.
6. All dimensions are consistent for KR-140 NPT or SAE ORB porting options, regardless of supply/outlet pressure and operator selection.

			
<p style="text-align: center; font-weight: bold; font-size: small;">PROPRIETARY AND CONFIDENTIAL</p> <p style="font-size: x-small;">THE INFORMATION CONTAINED IN THIS DRAWING IS THE SOLE PROPERTY OF PacSeal. ANY REPRODUCTION IN PART OR AS A WHOLE WITHOUT THE WRITTEN PERMISSION OF PacSeal Hydraulics IS PROHIBITED.</p>	<p><b>TITLE</b> Regulator w/ Failsafe Hydraulic Operator (NPT/SAE) Installation Drawing</p>	<p>SIZE <b>A</b></p>	<p>REV <b>7</b></p>
			<p>SHEET 6 OF 26</p>

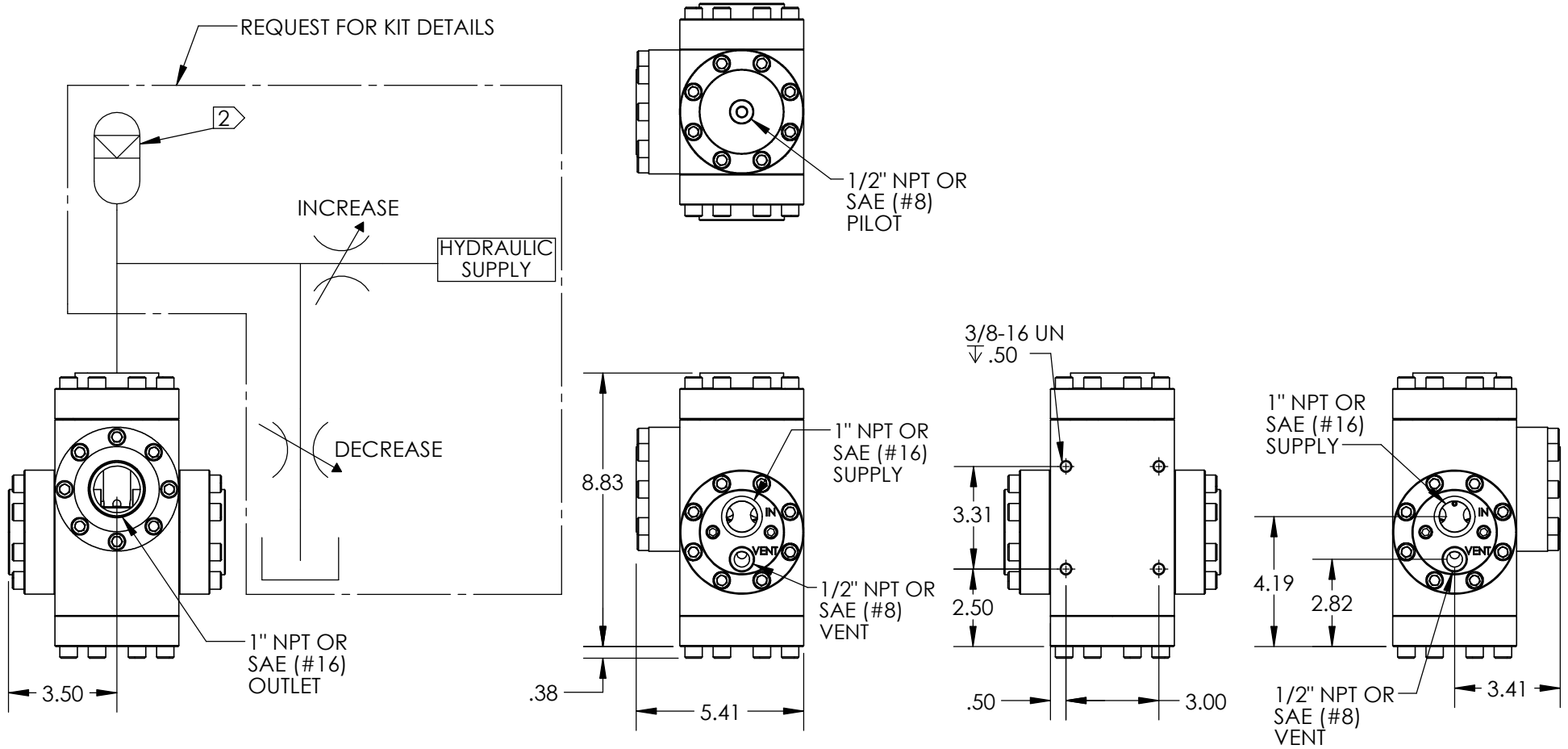

Notes:

1. A remote, variable hydraulic signal operates on a piston with a 1:1 ratio which allows for the most precisely controlled outlet pressures of all options. Loss of hydraulic pilot pressure will result in the outlet venting to tank.
- ② Requires a minimum 1 Pint Accumulator for operation
3. Model configuration (Regulated Outlet Pressure) option: P
4. Weight - 42 lb.
5. All dimensions are consistent for KR-140 NPT or SAE ORB porting options, regardless of supply/outlet pressure and operator selection.



**PROPRIETARY AND CONFIDENTIAL**  
THE INFORMATION CONTAINED IN THIS DRAWING IS THE SOLE PROPERTY OF PacSeal. ANY REPRODUCTION IN PART OR AS A WHOLE WITHOUT THE WRITTEN PERMISSION OF PacSeal IS PROHIBITED.

TITLE  
**Regulator w/ Hydraulic Pilot Operator (NPT/SAE) Installation Drawing**

SIZE <b>A</b>	REV <b>7</b>
SHEET 7 OF 26	



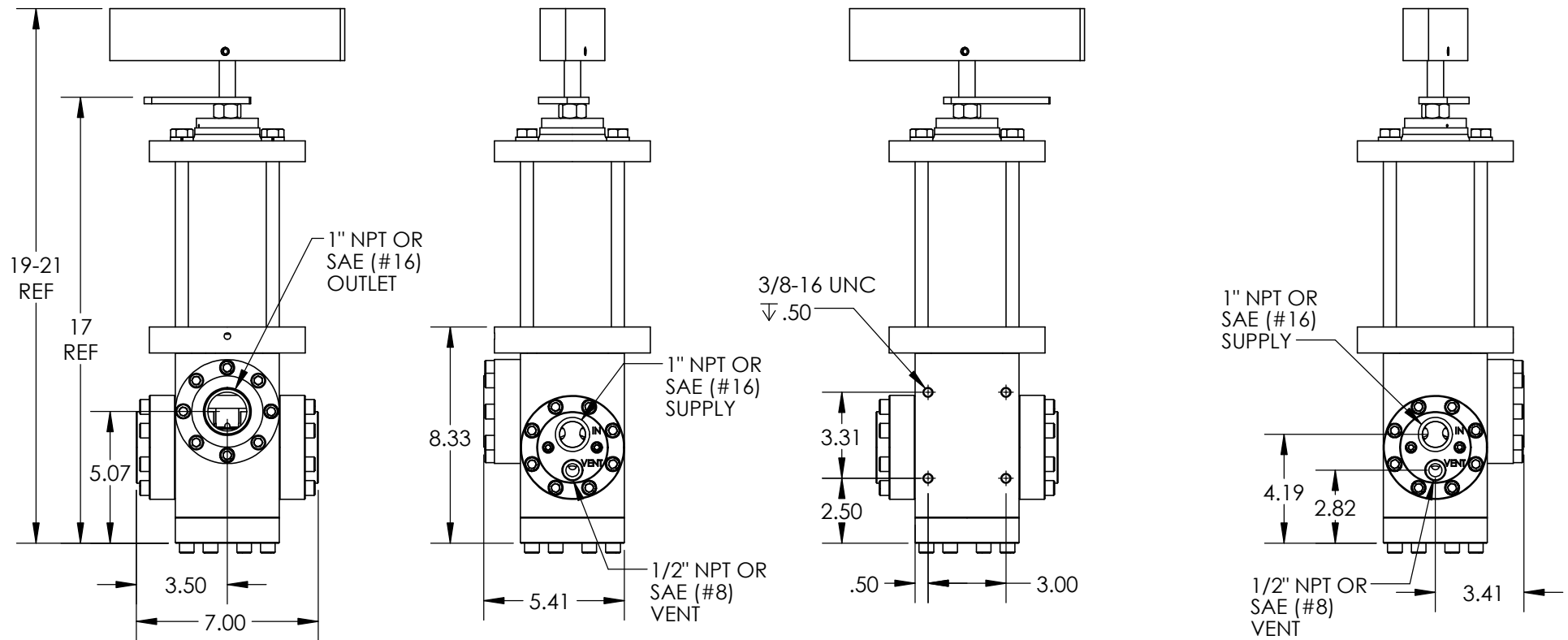

Notes:

1. Adjustment handle can be threaded in or out to increase or decrease compression on the spring and thus on the regulated outlet pressure.
2. Model configuration (Regulated Outlet Pressure) options: H (5000/6000 psi supply) and W (6000 psi supply).
3. Weight - 74 lb.
4. All dimensions are consistent for KR-140 NPT or SAE ORB porting options, regardless of supply/outlet pressure and operator selection.



**PROPRIETARY AND CONFIDENTIAL**  
 THE INFORMATION CONTAINED IN THIS DRAWING IS THE SOLE PROPERTY OF PacSeal. ANY REPRODUCTION IN PART OR AS A WHOLE WITHOUT THE WRITTEN PERMISSION OF PacSeal IS PROHIBITED.

TITLE **High Pressure Output w/ Manual Operator**

SIZE <b>A</b>	REV <b>7</b>
SHEET 9 OF 26	

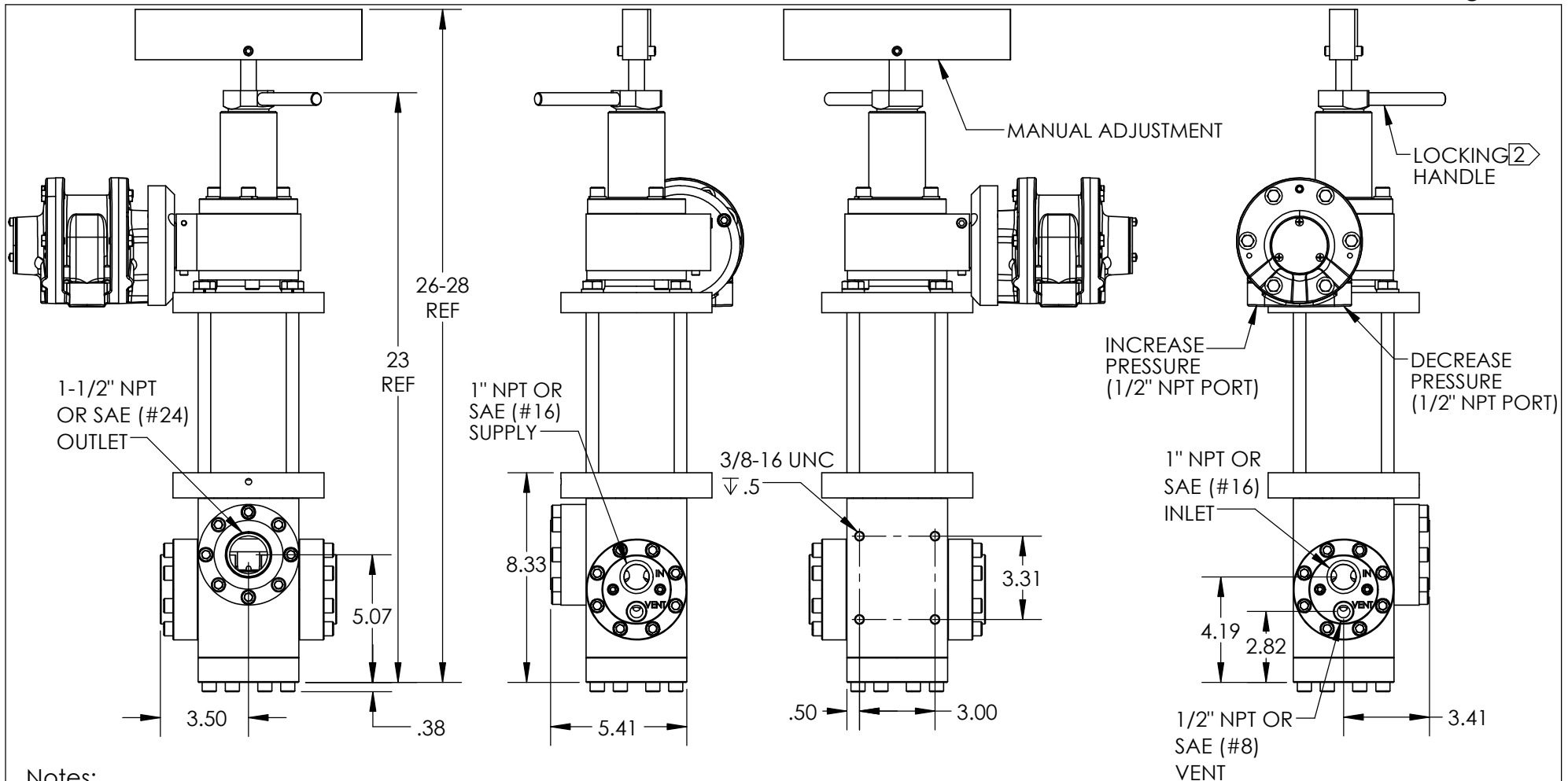

**Notes:**

1. Failsafe Air Motor provides remote operation with a manual override. Upon loss of pilot signal, there is no loss of regulated outlet pressure.
- ② Turn locking handle clockwise to lock for failsafe remote operation. Turn locking handle counter-clockwise to unlock for manual operation/override.
3. Recommended Air Supply - 115 PSI max with 1/2" tubing.
4. Model configuration (Regulated Outlet Pressure) option: H (5000 psi supply) and W (6000 psi supply)
5. Weight - 119 lb.
6. All dimensions are consistent for KR-140 NPT or SAE ORB porting options, regardless of supply/outlet pressure and operator selection.

			
<p style="text-align: center;"><b>PROPRIETARY AND CONFIDENTIAL</b></p> <p>THE INFORMATION CONTAINED IN THIS DRAWING IS THE SOLE PROPERTY OF PacSeal. ANY REPRODUCTION IN PART OR AS A WHOLE WITHOUT THE WRITTEN PERMISSION OF PacSeal Hydraulics IS PROHIBITED.</p>	<p><b>TITLE</b> High Pressure Output Regulator w/ High Torque Failsafe Air Operator</p>	<p>SIZE <b>A</b></p>	<p>REV <b>7</b></p>
			<p>SHEET 10 OF 26</p>



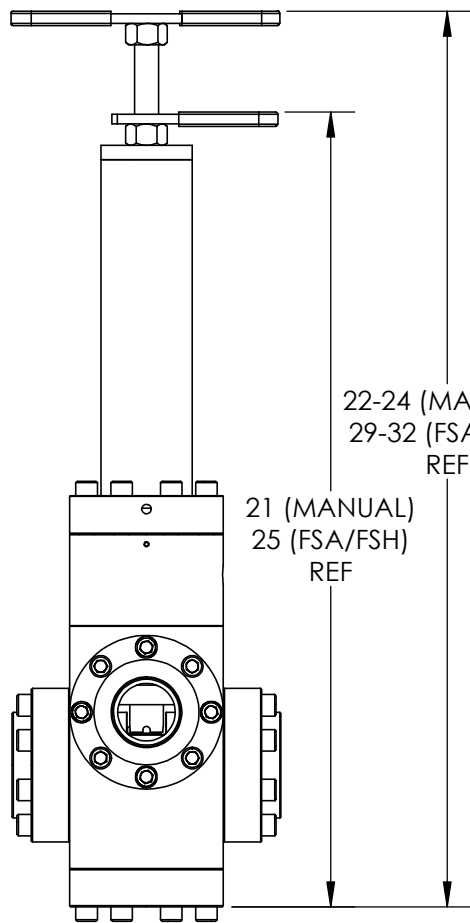

**KR-140 Internal Override Remote Pilot Operation (-IO)**

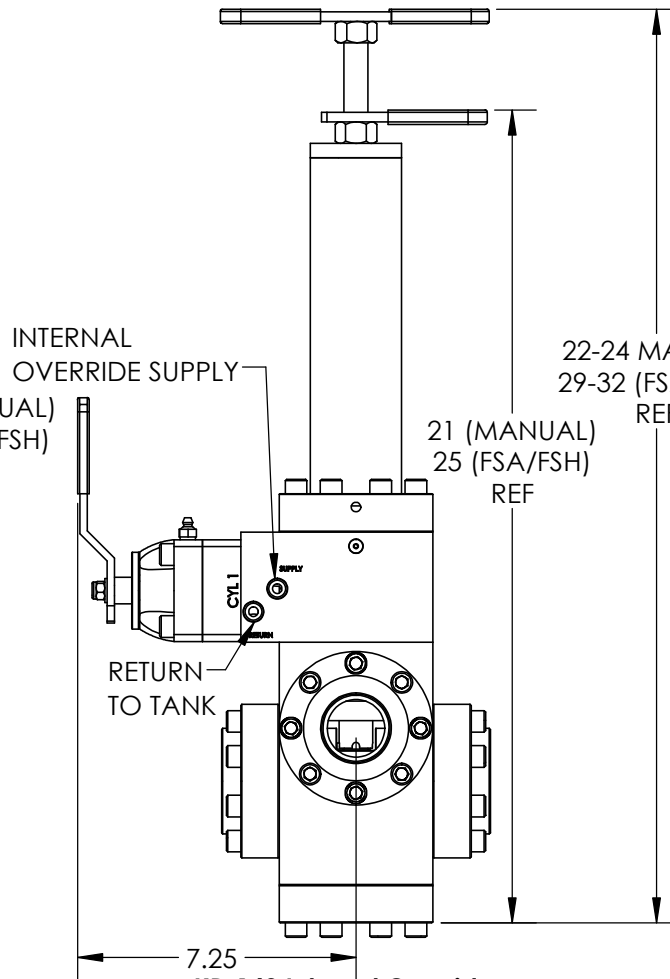

**KR-140 Internal Override with SV-25 Open Center Pilot Valve (-IS)**

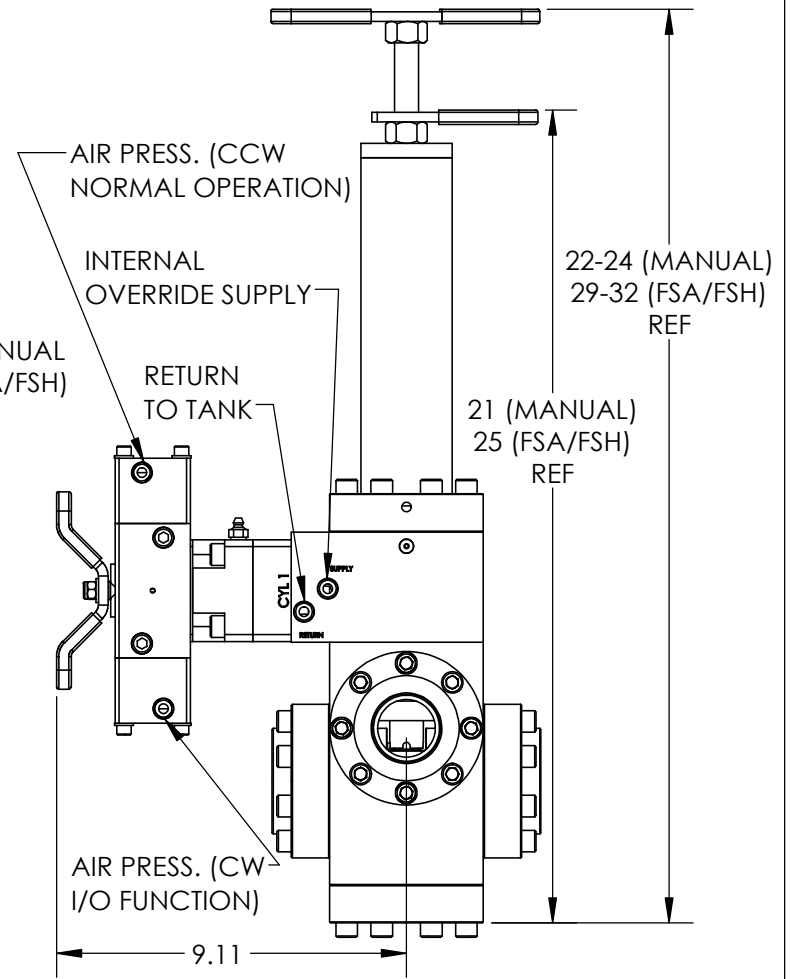

**KR-140 Internal Override with SVx-25 Open Center Pilot Air Actuated Valve (-IX) (80-150 psi air inlet) (3000 psi working pressure)**

The I/O Bypass operator allows full accumulator pressure to be supplied downstream of the regulator without a dedicated 4-way bypass valve in the circuit. The over-ride bypass is accomplished by applying a pilot signal to the I/O operator which is equal to or greater than the accumulator pressure. The pilot pressure forces the piston/ seal container assembly to the full open position where supply pressure flows through the regulator to the output circuit. Relieving the pilot signal allows the regulator to return to the original set pressure.

**Notes:**

- ① See SV-25 product information for further details
- ② See SVx-25 product information for further details
- 3. Regulated outlet pressure options: D, L, R, V



<p><b>PROPRIETARY AND CONFIDENTIAL</b></p> <p>THE INFORMATION CONTAINED IN THIS DRAWING IS THE SOLE PROPERTY OF PacSeal. ANY REPRODUCTION IN PART OR AS A WHOLE WITHOUT THE WRITTEN PERMISSION OF PacSeal IS PROHIBITED.</p>	<p>TITLE</p> <p><b>Internal Override Options Installation Drawing</b></p>	<p>SIZE</p> <p><b>A</b></p>	<p>REV</p> <p><b>7</b></p>
		<p>SHEET 12 OF 26</p>	

Notes:

1. KR-140 "R" Manual Regulator shown for illustration purposes.
2. All other regulated outlet pressure model configurations shown in sheets 14 - 17.
3. Failsafe motor and high pressure output operator assembly drawings shown in sheets 18 - 22.
4. Contact PacSeal for replacement parts.
5. Refer to KR-140 Maintenance Instructions for more details.

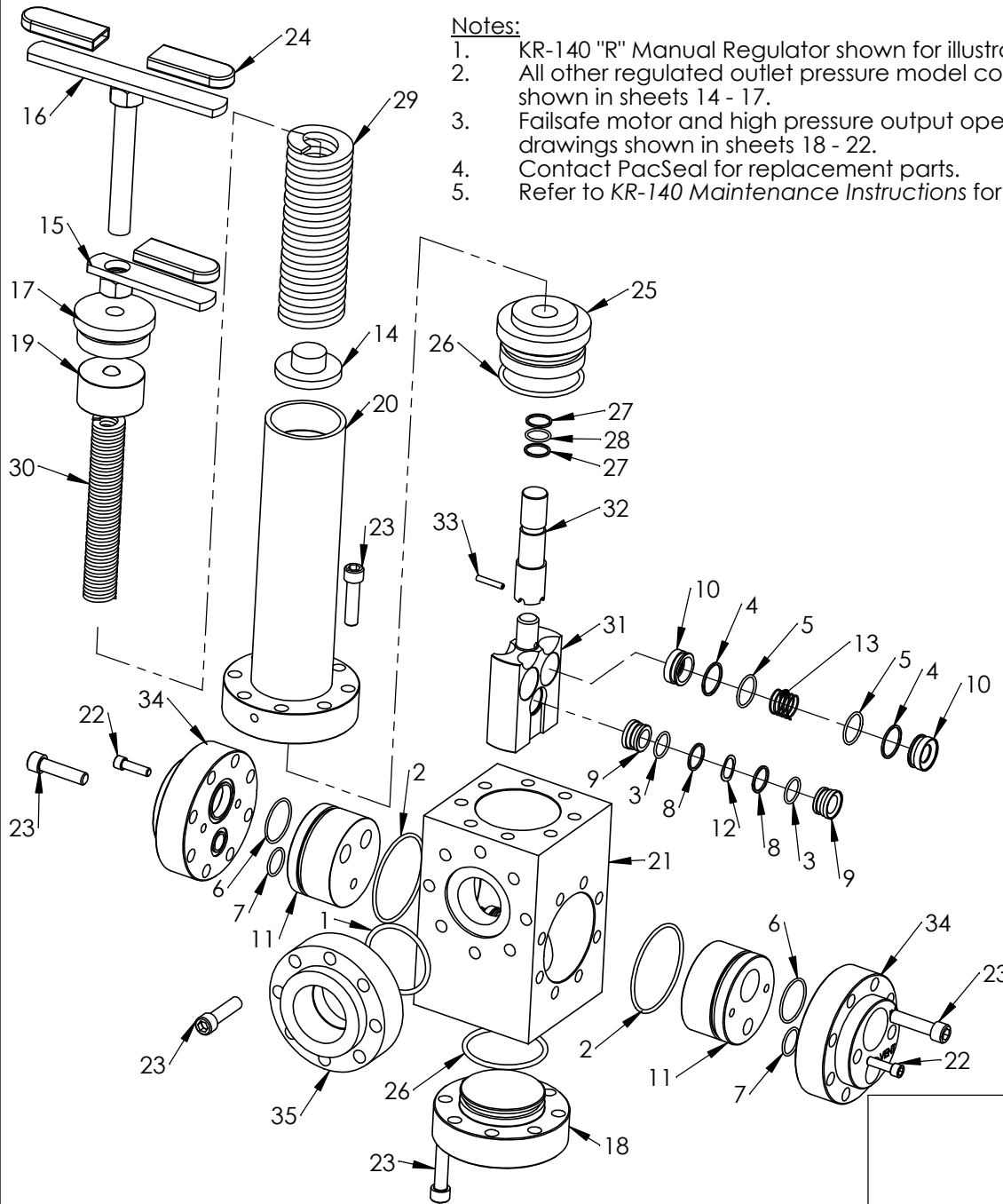

ITEM NO.	PART NUMBER	DESCRIPTION	QTY.
1	23-1126	O-Ring	1
2	23-1263	O-Ring	2
3	23-1293	O-Ring	2
4	23-1322	Backup Ring	4
5	23-1323	O-Ring	4
6	23-1325	O-Ring	2
7	23-1326	O-Ring	2
8	23-1329	Backup Ring	2
9	40-0013	Seal Ring, Vent	2
10	40-0014	Seal Ring, Supply	4
11	40-0016	Flow Plate	2
12	40-0109	Wave Spring	1
13	40-0110	Spring	2
14	40-0134	Spring Plate	1
15	40-0135	Lock Handle	1
16	40-0136	Adjusting Screw & Handle	1
17	40-0140	Plug, Adjustment Head	1
18	40-0197	Flange, Lower	1
19	40-0300	Spring Guide	1
20	40-0383	Adjustment Head	1
21	40-0950	Body	1
22	50-0066	Bolt, SHCS	4
23	50-0069	Bolt, SHCS	40
24	50-0239	Grip, Handle	3
25	Note 2	Piston Guide, KR-75	1
26	Note 2	O-Ring	2
27	Note 2	Backup Ring	2
28	Note 2	O-Ring	1
29	Note 2	Spring, Outer	1
30	Note 2	Spring, Inner	1
31	Note 2	Seal Container	1
32	Note 2	Piston	1
33	Note 2	Roll Pin	1
34	Note 4	Flange, Main	2
35	Note 4	Flange, Outlet	1



<p><b>PROPRIETARY AND CONFIDENTIAL</b></p> <p>THE INFORMATION CONTAINED IN THIS DRAWING IS THE SOLE PROPERTY OF PacSeal. ANY REPRODUCTION IN PART OR AS A WHOLE WITHOUT THE WRITTEN PERMISSION OF PacSeal Hydraulics IS PROHIBITED.</p>	TITLE	SIZE	REV
	<b>General Assembly Overview</b>	<b>A</b>	<b>7</b>
	SHEET 13 OF 26		

**Notes:**

- The listed components vary based on Supply and Regulated Outlet Pressures, while all other components (shown in sheet 13 "General Assembly Overview") are shared.

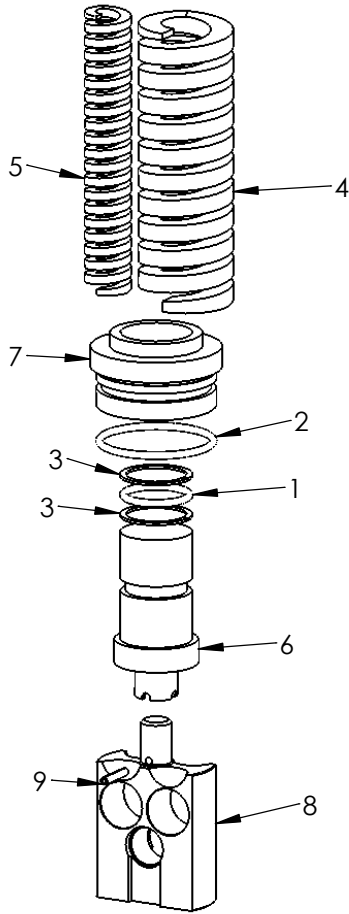

**KR-140 "L" Regulator**

Model	Supply Pressure (psi)	Regulated Outlet Pressure (psi)	Deadband (psi)
L	3000/5000	200-2000	85-150
H	5000/6000	350-3300	85-150

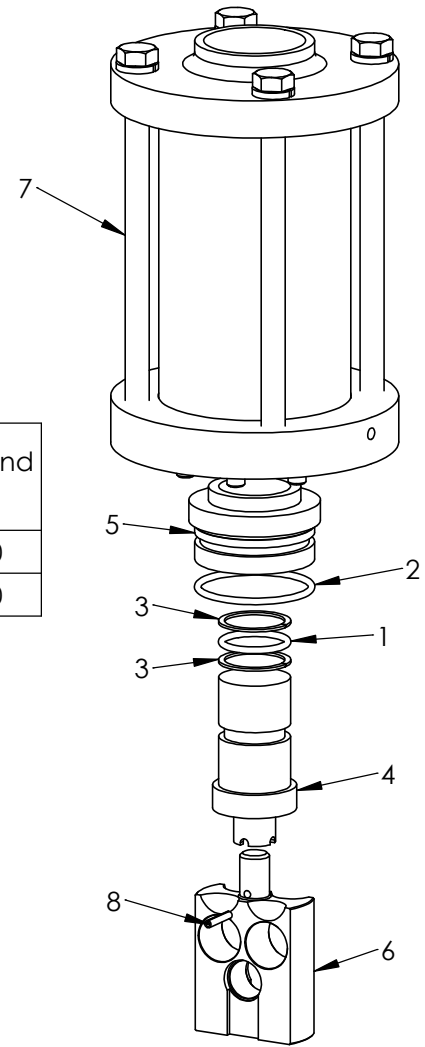

**KR-140 "H" Regulator  
with High Pressure Output  
Adjustment Head**

ITEM NO.	PART NUMBER	DESCRIPTION	QTY.
1	23-1124	O-Ring	1
2	23-1319	O-Ring	1
3	23-1342	Backup Ring	2
4	40-0143	Spring, Outer	1
5	40-0144	Spring, Inner	1
6	40-0995	Piston, L	1
7	40-0996	Plunger Guide, L	1
8	40-1292	Seal Container	1
9	50-0117	Roll Pin	1

ITEM NO.	PART NUMBER	DESCRIPTION	QTY.
1	23-1124	O-Ring	1
2	23-1319	O-Ring	1
3	23-1342	Backup Ring	2
4	40-0995	Piston, L	1
5	40-0996	Piston Guide, L	1
6	40-1292	Seal Container	1
7	40-2927	High Pressure Output Adj. Head	1
8	50-0117	Roll Pin	1



**PROPRIETARY AND CONFIDENTIAL**  
THE INFORMATION CONTAINED IN THIS DRAWING IS THE SOLE PROPERTY OF PacSeal. ANY REPRODUCTION IN PART OR AS A WHOLE WITHOUT THE WRITTEN PERMISSION OF PacSeal IS PROHIBITED.

**TITLE**  
**L and H Model  
Configurations  
Assembly Drawing**

**SIZE**  
**A**

**REV**  
**7**

SHEET 14 OF 26

**Notes:**

1. The listed components vary based on Supply and Regulated Outlet Pressures, while all other components (shown in sheet 13 "General Assembly Overview") are shared.

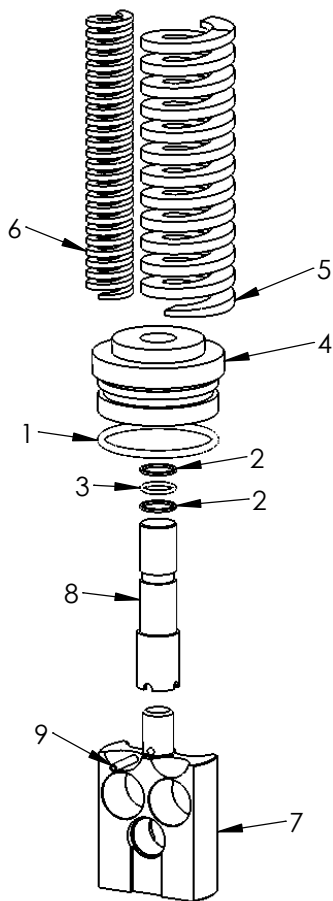

**KR-140 "R" Regulator**

Model	Supply Pressure (psi)	Regulated Outlet Pressure (psi)	Deadband (psi)
R	3000/5000	550-2500	300-600
V	6000	1200-5500	450-800

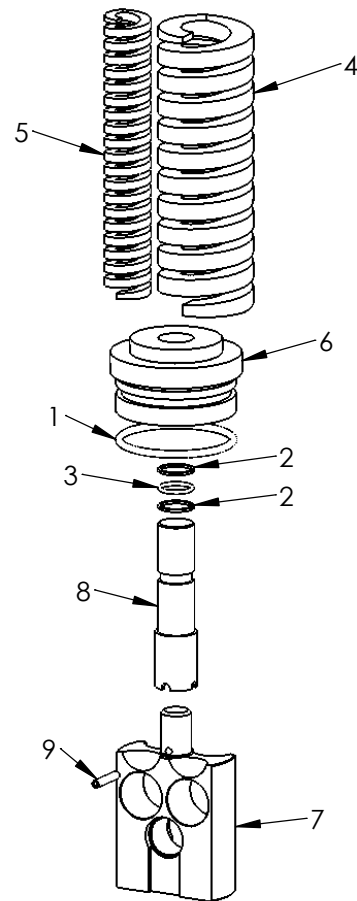

**KR-140 "V" Regulator**

ITEM NO.	PART NUMBER	DESCRIPTION	QTY.
1	23-1319	O-Ring	1
2	23-1320	Backup Ring	2
3	23-1321	O-Ring	1
4	40-0186	Piston Guide, R	1
5	40-0189	Spring, Outer	1
6	40-0190	Spring, Inner	1
7	40-1292	Seal Container	1
8	40-2875	Piston, R	1
9	50-0117	Roll Pin	1

ITEM NO.	PART NUMBER	DESCRIPTION	QTY.
1	23-1319	O-Ring	1
2	23-1320	Backup Ring	2
3	23-1321	O-Ring	1
4	40-0143	Spring, Outer	1
5	40-0144	Spring, Inner	1
6	40-0186	Piston Guide, R	1
7	40-1292	Seal Container	1
8	40-2875	Piston, R	1
9	50-0117	Roll Pin	1



**PROPRIETARY AND CONFIDENTIAL**  
 THE INFORMATION CONTAINED IN THIS DRAWING IS THE SOLE PROPERTY OF PacSeal.  
 ANY REPRODUCTION IN PART OR AS A WHOLE WITHOUT THE WRITTEN PERMISSION OF PacSeal IS PROHIBITED.

TITLE **R and V Model Configurations Assembly Drawing**

SIZE **A** REV **7**

**Notes:**

1. The listed components vary based on Supply and Regulated Outlet Pressures, while all other components (shown in sheet 13 "General Assembly Overview") are shared.

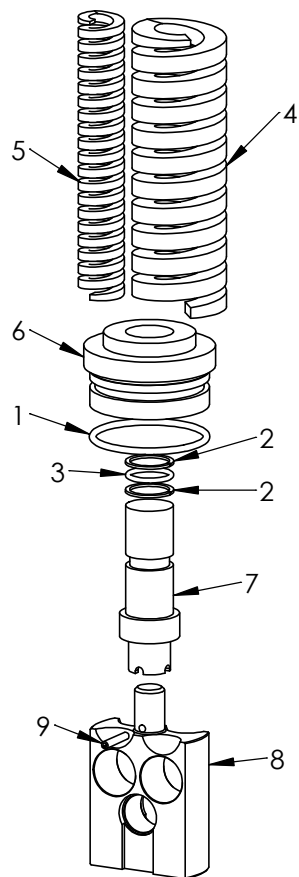

**KR-140 "D" Regulator**

Model	Supply Pressure (psi)	Regulated Outlet Pressure (psi)	Deadband (psi)
D	5000/6000	400-4000	150-250
W	6000	600-5000	150-250

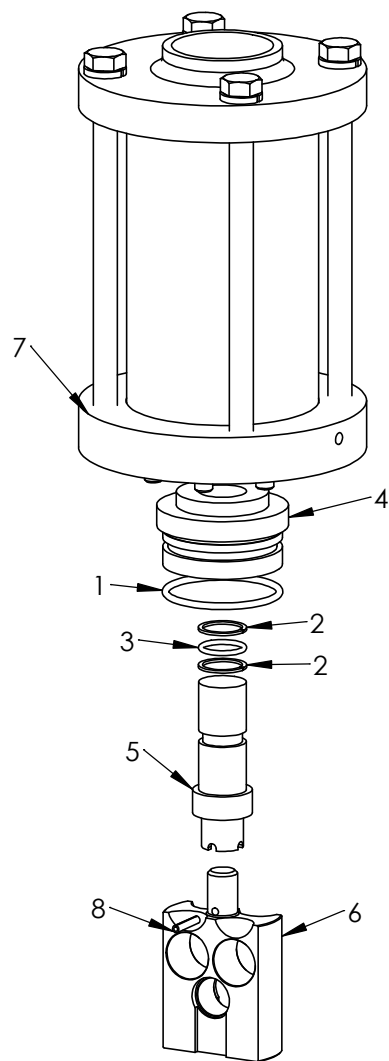

**KR-140 "W" Regulator  
with High Pressure Output  
Adjustment Head**

ITEM NO.	PART NUMBER	DESCRIPTION	QTY.
1	23-1319	O-Ring	1
2	23-1331	Backup Ring	2
3	23-1332	O-Ring	1
4	40-0143	Spring, Outer	1
5	40-0144	Spring, Inner	1
6	40-1076	Piston Guide, D	1
7	40-1077	Piston, D	1
8	40-1292	Seal Container	1
9	50-0117	Roll Pin	1

ITEM NO.	PART NUMBER	DESCRIPTION	QTY.
1	23-1319	O-Ring	1
2	23-1331	Backup Ring	2
3	23-1332	O-Ring	1
4	40-1076	Piston Guide, D	1
5	40-1077	Piston, D	1
6	40-1292	Seal Container	1
7	40-2927	High Pressure Output Adj. Head	1
8	50-0117	Roll Pin	1



**PROPRIETARY AND CONFIDENTIAL**  
THE INFORMATION CONTAINED IN THIS DRAWING IS THE SOLE PROPERTY OF PacSeal. ANY REPRODUCTION IN PART OR AS A WHOLE WITHOUT THE WRITTEN PERMISSION OF PacSeal IS PROHIBITED.

**TITLE** D and W Model Configurations Assembly Drawing

**SIZE** A **REV** 7  
SHEET 16 OF 26

Notes:

- The listed components vary based on Supply and Regulated Outlet Pressures, while all other components (shown in sheet 13 "General Assembly Overview") are shared.

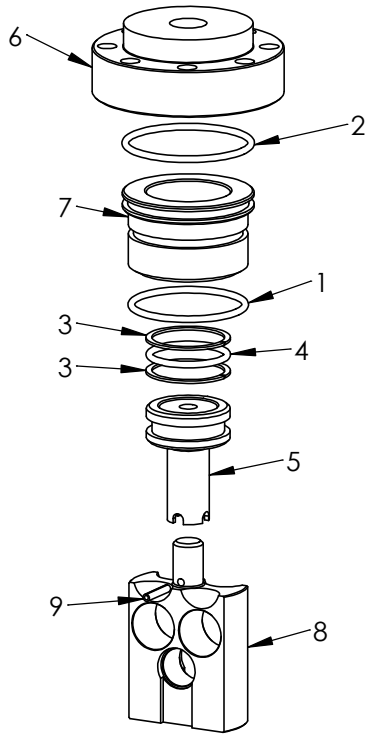

Model	Supply Pressure (psi)	Regulated Outlet Pressure (psi)	Deadband (psi)
P	3000/5000/6000	50-6000	0-100

**KR-140 "P" Regulator  
(Hydraulic Pilot)**

ITEM NO.	PART NUMBER	DESCRIPTION	QTY.
1	23-1319	O-Ring	1
2	23-1327	O-Ring	1
3	23-1328	Backup Ring	2
4	23-1529	O-Ring	1
5	40-0183	Piston, A/H	1
6	40-0298	Hydraulic Head	1
7	40-0299	Piston Guide	1
8	40-1292	Seal Container	1
9	50-0117	Roll Pin	1



**PROPRIETARY AND CONFIDENTIAL**  
 THE INFORMATION CONTAINED IN THIS DRAWING IS THE SOLE PROPERTY OF PacSeal. ANY REPRODUCTION IN PART OR AS A WHOLE WITHOUT THE WRITTEN PERMISSION OF PacSeal IS PROHIBITED.

**TITLE**  
**P Model Configuration Assembly Drawing**

<b>SIZE</b> <b>A</b>	<b>REV</b> <b>7</b>
-------------------------	------------------------

SHEET 17 OF 26

ITEM NO.	PART NUMBER	DESCRIPTION	QTY.
1	23-1123	O-Ring	1
2	23-1356	O-Ring	1
3	23-1385	O-Ring	1
4	23-1404	O-Ring	1
5	23-1405	O-Ring	1
6	40-0414	Adapter Plate	1
7	40-0416	Failsafe Collar	1
8	40-0418	Failsafe Handle	1
9	40-0419	Shaft Extension, Failsafe Air	1
10	40-0543	Motor, Failsafe Air Standard	1
11	40-2742	Worm	1
12	40-3960	Fail Safe Shaft, KR	1
13	40-3962	Housing, KR Shaft Adjustment	1
14	40-3964	Failsafe Nut Assy	1
15	40-4978	Failsafe Body	1
16	40-4979	Worm Gear	1
17	50-0072	Screw	6
18	50-0103	Lock Washer	3
19	50-0154	Roll Pin	1
20	50-0156	Screw	1
21	50-0157B	Bearing, NTA-1220	1
22	50-0157T	Thrust Washer, TRB-1220	2
23	50-0158	Roller Bearing	1
24	50-0160	Set Screw	2
25	50-0223	Set Screw	2
26	50-0287	Roll Pin	1
27	50-0483	Roller Bearing	1
28	50-0686	Bearing	1
29	50-0687	Thrust Washer	2

**Failsafe Air Operator (40-3963)**

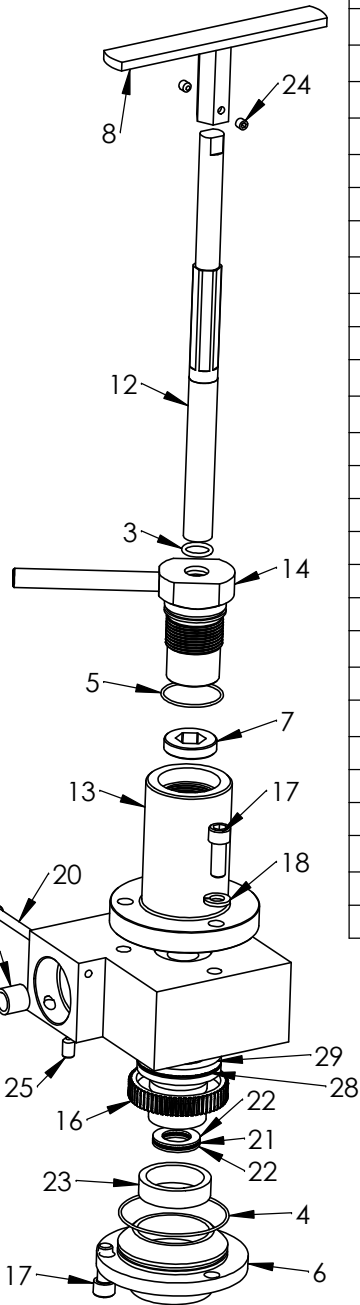

ITEM NO.	PART NUMBER	DESCRIPTION	QTY.
1	23-1123	O-Ring	1
2	23-1356	O-Ring	1
3	23-1385	O-Ring	1
4	23-1404	O-Ring	1
5	23-1405	O-Ring	1
6	40-0414	Adapter Plate	1
7	40-0416	Failsafe Collar	1
8	40-0418	Failsafe Handle	1
9	40-0715	Hydraulic Adapter	1
10	40-0719	Motor, Failsafe Hydraulic	1
11	40-2742	Worm	1
12	40-3960	Failsafe Shaft	1
13	40-3962	Housing, KR Shaft Adjustment	1
14	40-3964	Failsafe Nut Assy	1
15	40-4978	Failsafe Body	1
16	40-4979	Worm Gear	1
17	50-0072	Screw	6
18	50-0103	Lock Washer	3
19	50-0154	Roll Pin	1
20	50-0156	Screw	1
21	50-0157B	Bearing	1
22	50-0157T	Thrust Washer	2
23	50-0158	Roller Bearing	1
24	50-0160	Set Screw	2
25	50-0215	Screw	4
26	50-0223	Set Screw	2
27	50-0483	Roller Bearing	1
28	50-0686	Thrust Bearing, NTA-2435	1
29	50-0687	Thrust Washer, TRF-2435	2

**Failsafe Hydraulic Operator (40-4255)**

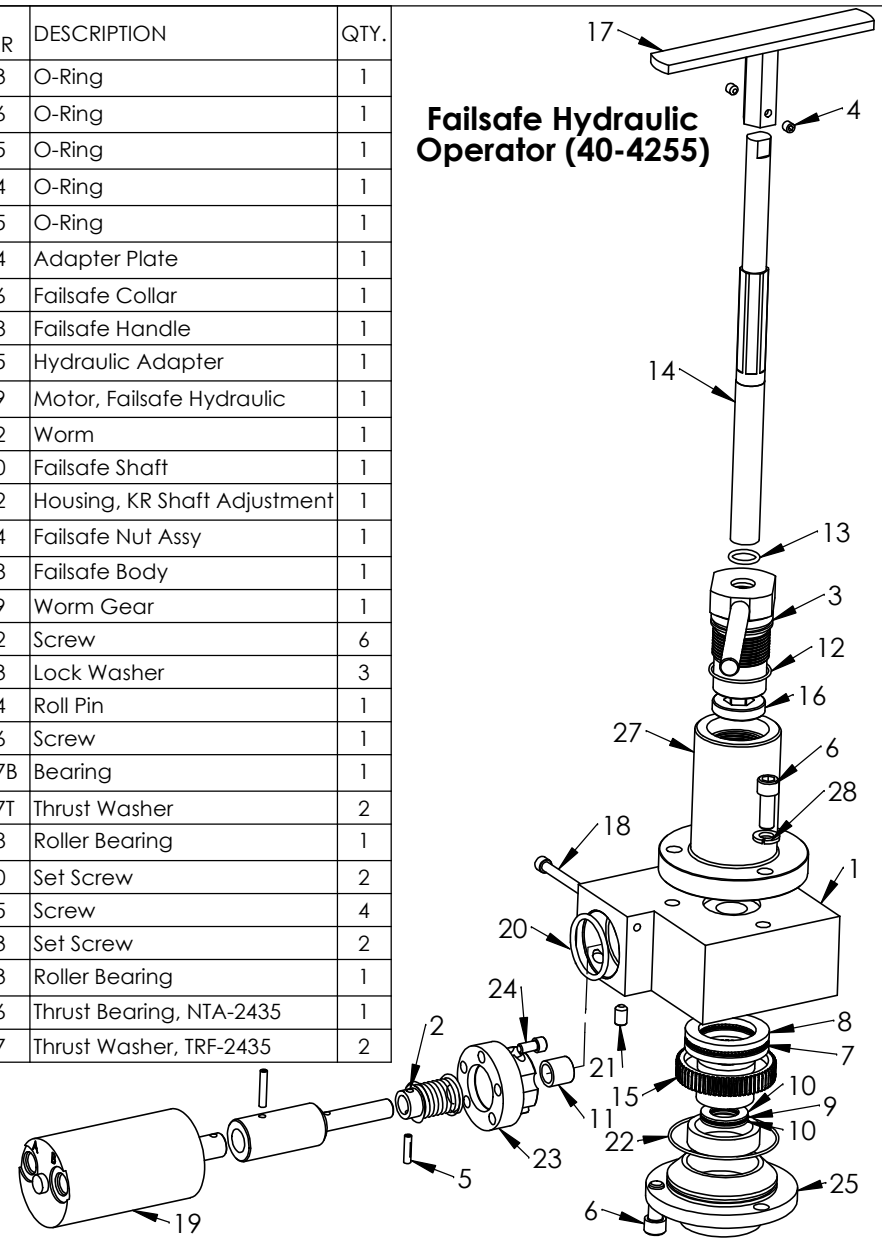

**PROPRIETARY AND CONFIDENTIAL**  
 THE INFORMATION CONTAINED IN THIS DRAWING IS THE SOLE PROPERTY OF PacSeal. ANY REPRODUCTION IN PART OR AS A WHOLE WITHOUT THE WRITTEN PERMISSION OF PacSeal IS PROHIBITED.

**TITLE** Failsafe Air and Hydraulic Operators Assembly Drawing

SIZE <b>A</b>	REV <b>7</b>
SHEET 18 OF 26	

ITEM NO.	PART NUMBER	DESCRIPTION	QTY.
1	40-2654	Plate, Upper Actuator	1
2	40-2655	Plate, Upper Spring	1
3	40-2656	Cylinder, Actuator	1
4	40-2657	Plate, Lower Spring	1
5	40-2658	Plate, Lower Actuator	1
6	40-2659	Spring, Outer	3
7	40-2660	Spring, Inner	3
8	50-0072	SHCS	8
9	50-0104	Lock Washer	4
10	50-0434	Bolt	4
11	50-0435	Rod	1

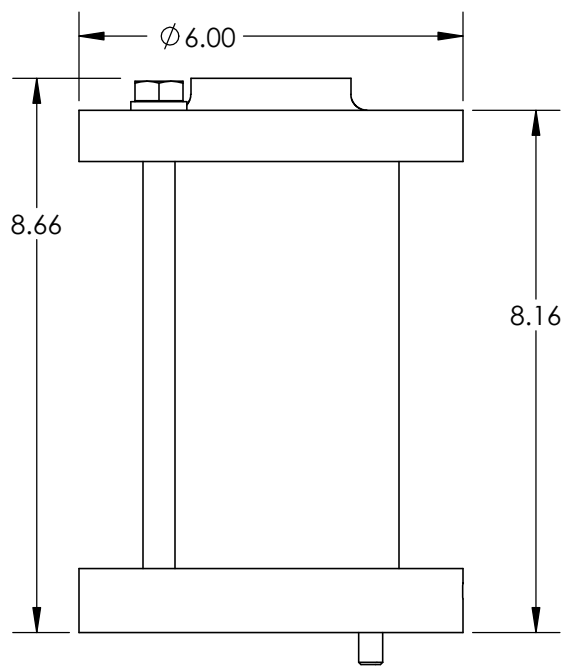
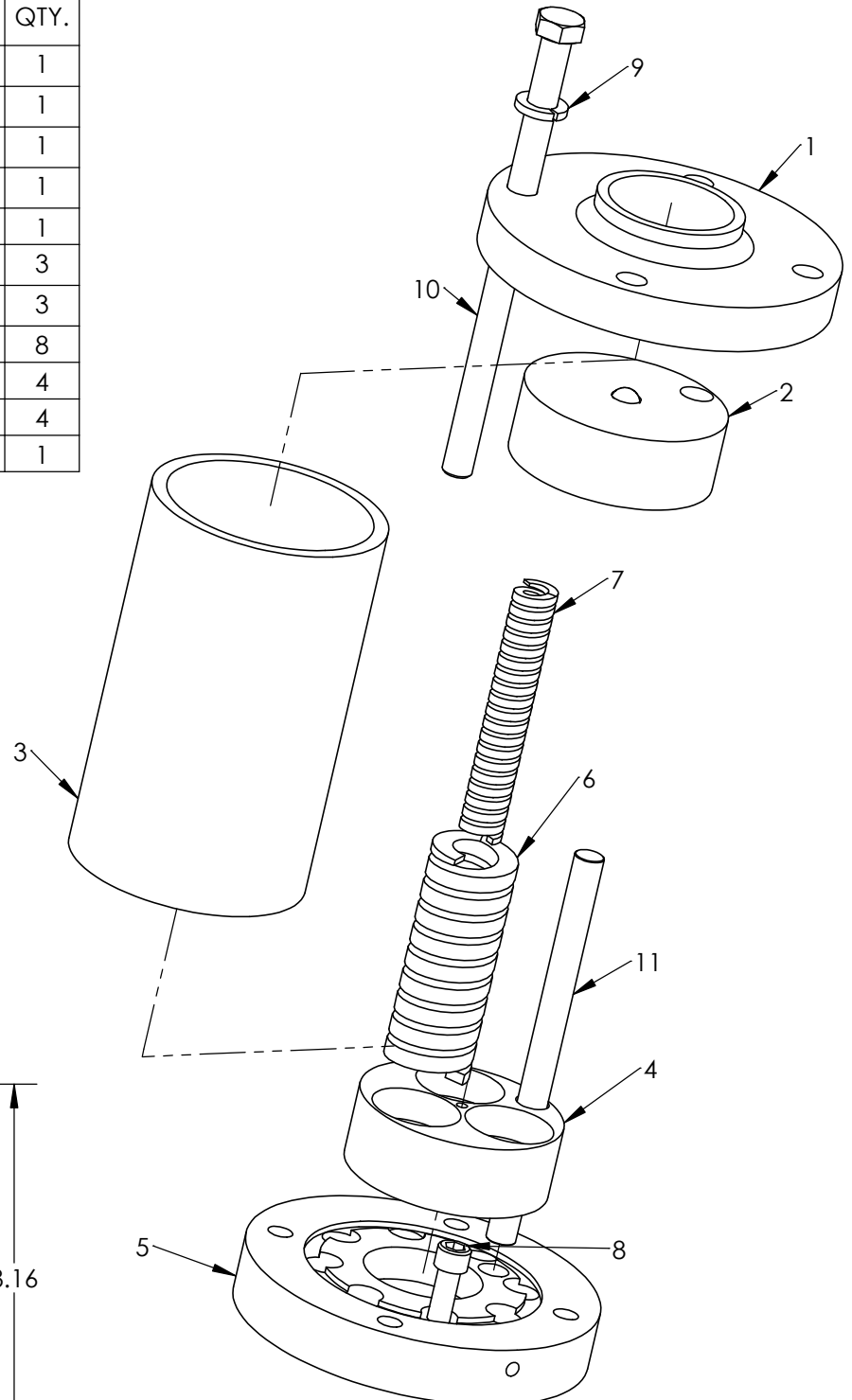

**KIT PART NUMBER**  
**40-2927**



**PROPRIETARY AND CONFIDENTIAL**  
THE INFORMATION CONTAINED IN THIS DRAWING IS THE SOLE PROPERTY OF PacSeal. ANY REPRODUCTION IN PART OR AS A WHOLE WITHOUT THE WRITTEN PERMISSION OF PacSeal IS PROHIBITED.

TITLE  
**High Pressure Output Adjustment Head Assembly Drawing**

SIZE <b>A</b>	REV <b>7</b>
SHEET 19 OF 26	

ITEM NO.	PART NUMBER	DESCRIPTION	QTY.
1	40-0135	Lock Handle	1
2	40-0140	Plug, Adjustment Head	1
3	40-3237	Handle, Fail Safe HP	1
4	40-3414	Adjusting Rod	1
5	50-0482	Set Screw	2

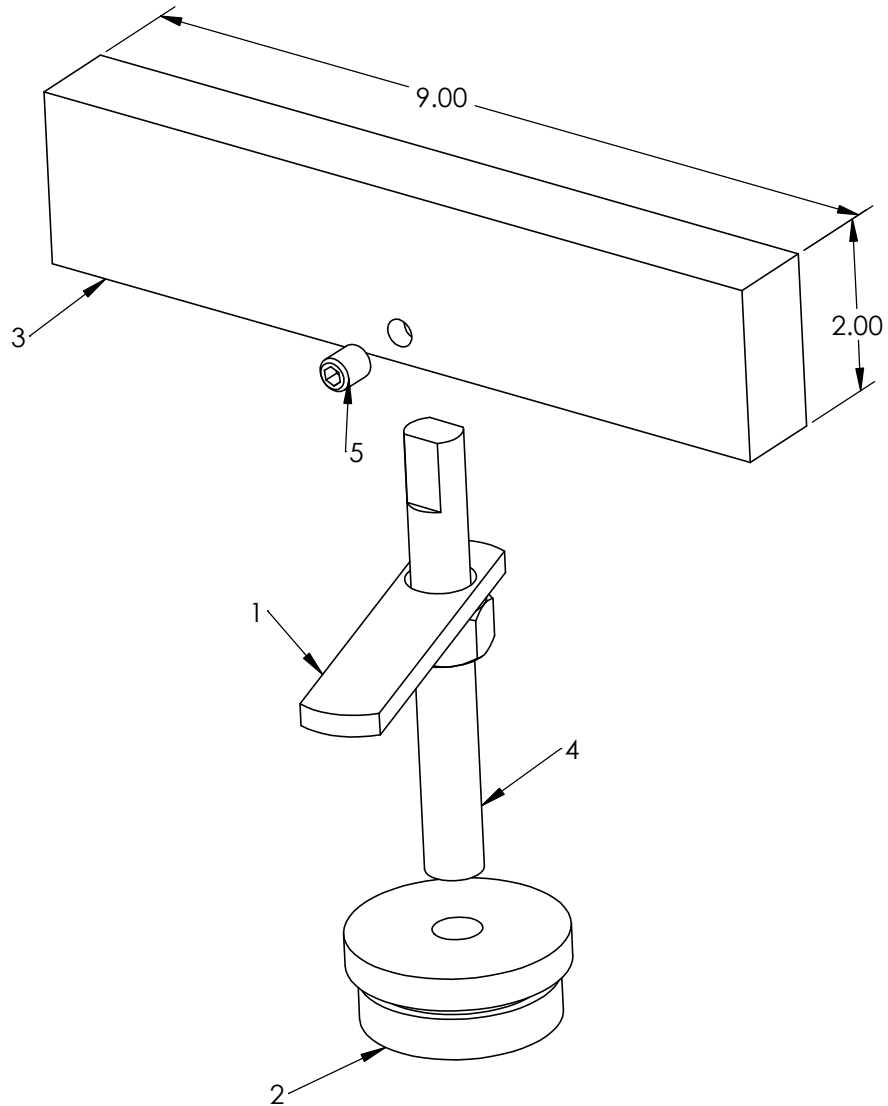

**KIT PART NUMBER**  
**40-3558**



**PROPRIETARY AND CONFIDENTIAL**  
 THE INFORMATION CONTAINED IN THIS DRAWING IS THE SOLE PROPERTY OF PacSeal. ANY REPRODUCTION IN PART OR AS A WHOLE WITHOUT THE WRITTEN PERMISSION OF PacSeal IS PROHIBITED.

TITLE  
**High Pressure Output  
 Manual Handle  
 Assembly Drawing**

SIZE	REV
<b>A</b>	<b>7</b>

SHEET 20 OF 26

**High Pressure Output Failsafe Air Actuator  
(40-4982) with Standard Motor**  
*Used exclusively with "H" and "W" Regulators*

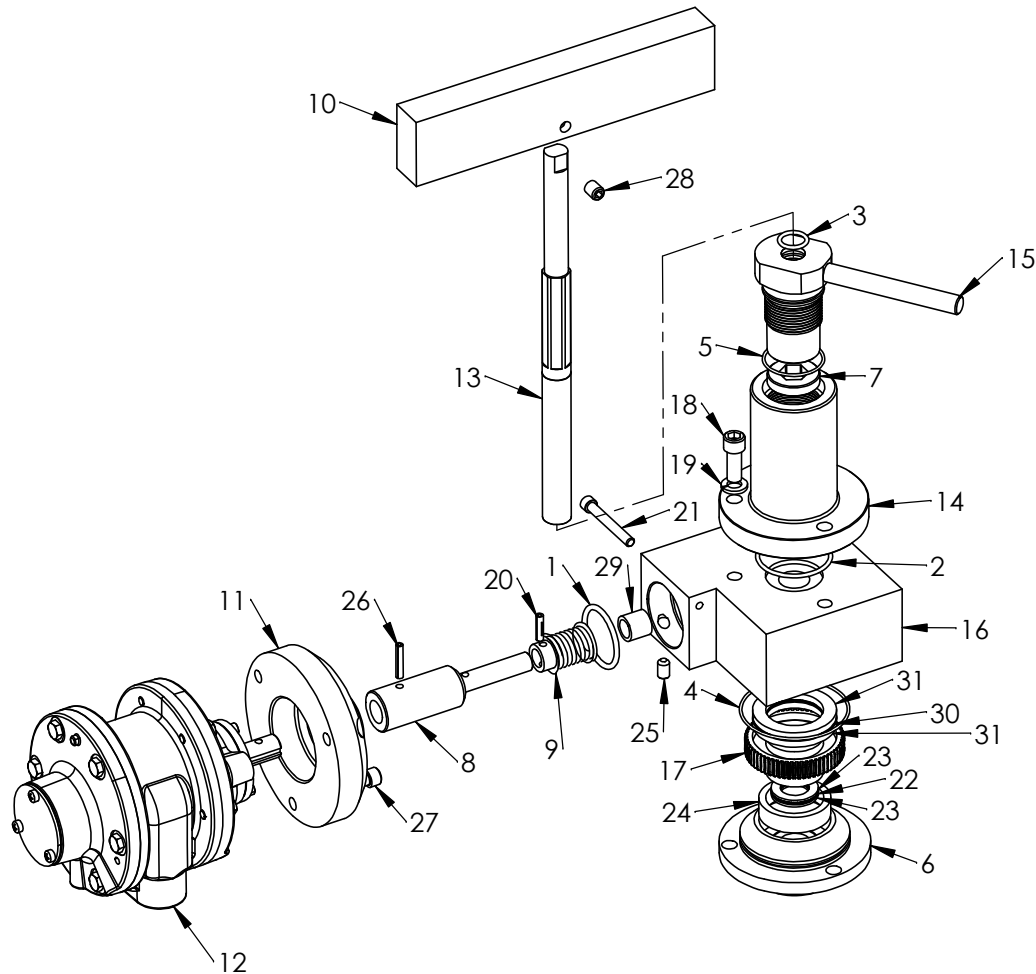

ITEM NO.	PART NUMBER	DESCRIPTION	QTY.
1	23-1123	O-Ring	1
2	23-1356	O-Ring	1
3	23-1385	O-Ring	1
4	23-1404	O-Ring	1
5	23-1405	O-Ring	1
6	40-0414	Adapter Plate, FailSafe	1
7	40-0416	Fail Safe Collar	1
8	40-0716	Shaft Extension	1
9	40-2742	Worm	1
10	40-3237	Handle, Fail Safe HP	1
11	40-3757	Adapter Plate	1
12	40-3761	Air Motor	1
13	40-3960	Fail Safe Shaft	1
14	40-3962	Housing	1
15	40-3964	Fail Safe Nut Assy	1
16	40-4978	Fail Safe Body	1
17	40-4979	Worm Gear, FailSafe	1
18	50-0072	Screw	6
19	50-0103	Lock Washer	3
20	50-0154	Roll Pin	1
21	50-0156	Screw	1
22	50-0157B	Bearing	1
23	50-0157T	Thrust Washer	2
24	50-0158	Roller Bearing	1
25	50-0223	Set Screw	2
26	50-0287	Roll Pin	1
27	50-0319	Screw	3
28	50-0482	Set Screw	2
29	50-0483	Roller Bearing	1
30	50-0686	Thrust Bearing	1
31	50-0687	Thrust Washer	2



**PROPRIETARY AND CONFIDENTIAL**

THE INFORMATION CONTAINED IN THIS DRAWING IS THE SOLE PROPERTY OF PacSeal. ANY REPRODUCTION IN PART OR AS A WHOLE WITHOUT THE WRITTEN PERMISSION OF PacSeal IS PROHIBITED.

TITLE

**High Pressure Output  
Failsafe Air Operators  
Assembly Drawing**

SIZE  
**A**

REV  
**7**

SHEET 21 OF 26

**High Pressure Output Failsafe Hydraulic Actuator  
(40-4981) with High Torque Motor**  
Used exclusively with "H" and "W" Regulator

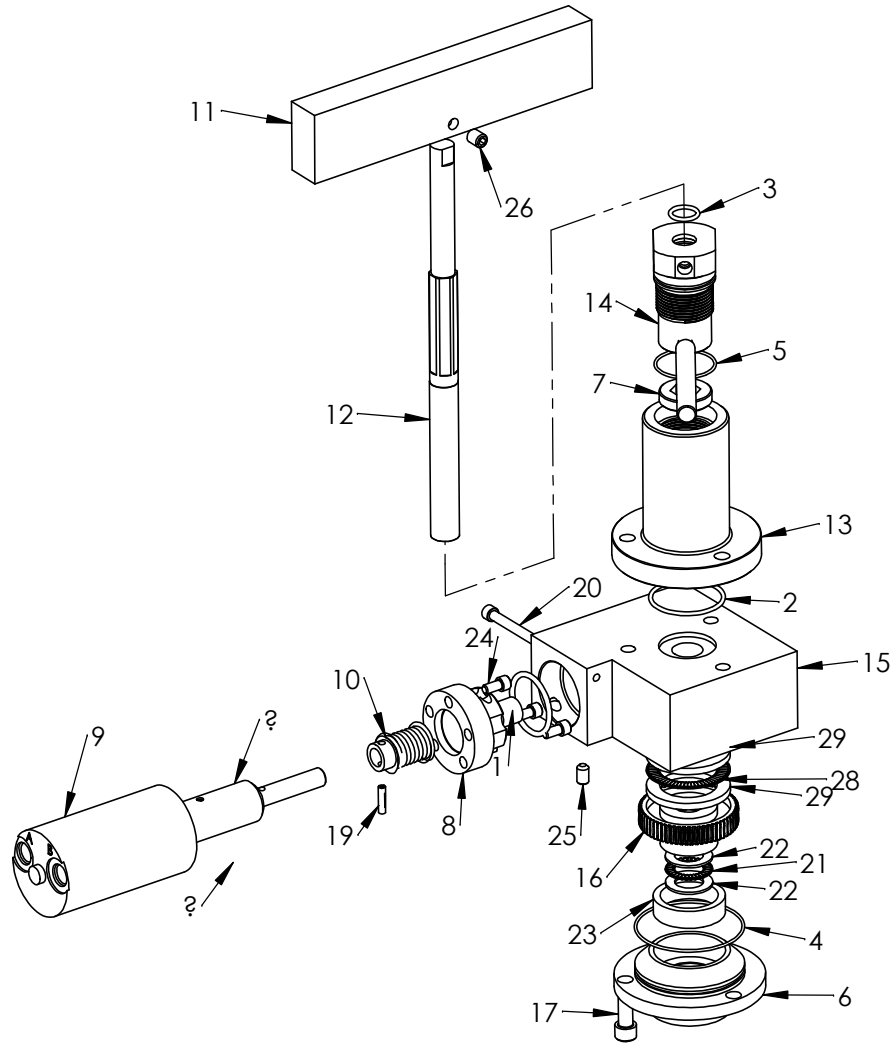

ITEM NO.	PART NUMBER	DESCRIPTION	QTY.
1	23-1123	O-Ring	1
2	23-1356	O-Ring	1
3	23-1385	O-Ring	1
4	23-1404	O-Ring	1
5	23-1405	O-Ring	1
6	40-0414	Adapter Plate	1
7	40-0416	Fail Safe Collar	1
8	40-0715	Hydraulic Adapter	1
9	40-0719	Motor, Hydraulic	1
10	40-2742	Worm	1
11	40-3237	Handle, Fail Safe HP	1
12	40-3960	Fail Safe Shaft	1
13	40-3962	Housing	1
14	40-3964	Fail Safe Nut Assy	1
15	40-4978	Fail Safe Body	1
16	40-4979	Worm Gear	1
17	50-0072	Screw	6
18	50-0103	Lock Washer	3
19	50-0154	Roll Pin	1
20	50-0156	Screw	1
21	50-0157B	Bearing	1
22	50-0157T	Thrust Washer	2
23	50-0158	Roller Bearing	1
24	50-0215	Screw	5
25	50-0223	Set Screw	2
26	50-0482	Set Screw	2
27	50-0483	Roller Bearing	1
28	50-0686	Thrust Bearing	1
29	50-0687	Thrust Washer	2



**PROPRIETARY AND CONFIDENTIAL**

THE INFORMATION CONTAINED IN THIS DRAWING IS THE SOLE PROPERTY OF PacSeal. ANY REPRODUCTION IN PART OR AS A WHOLE WITHOUT THE WRITTEN PERMISSION OF PacSeal IS PROHIBITED.

TITLE  
**High Pressure Output  
Failsafe Hydraulic Operator  
Assembly Drawing**

SIZE <b>A</b>	REV <b>7</b>
SHEET 22 OF 26	

KIT PART NUMBER  
40-4886

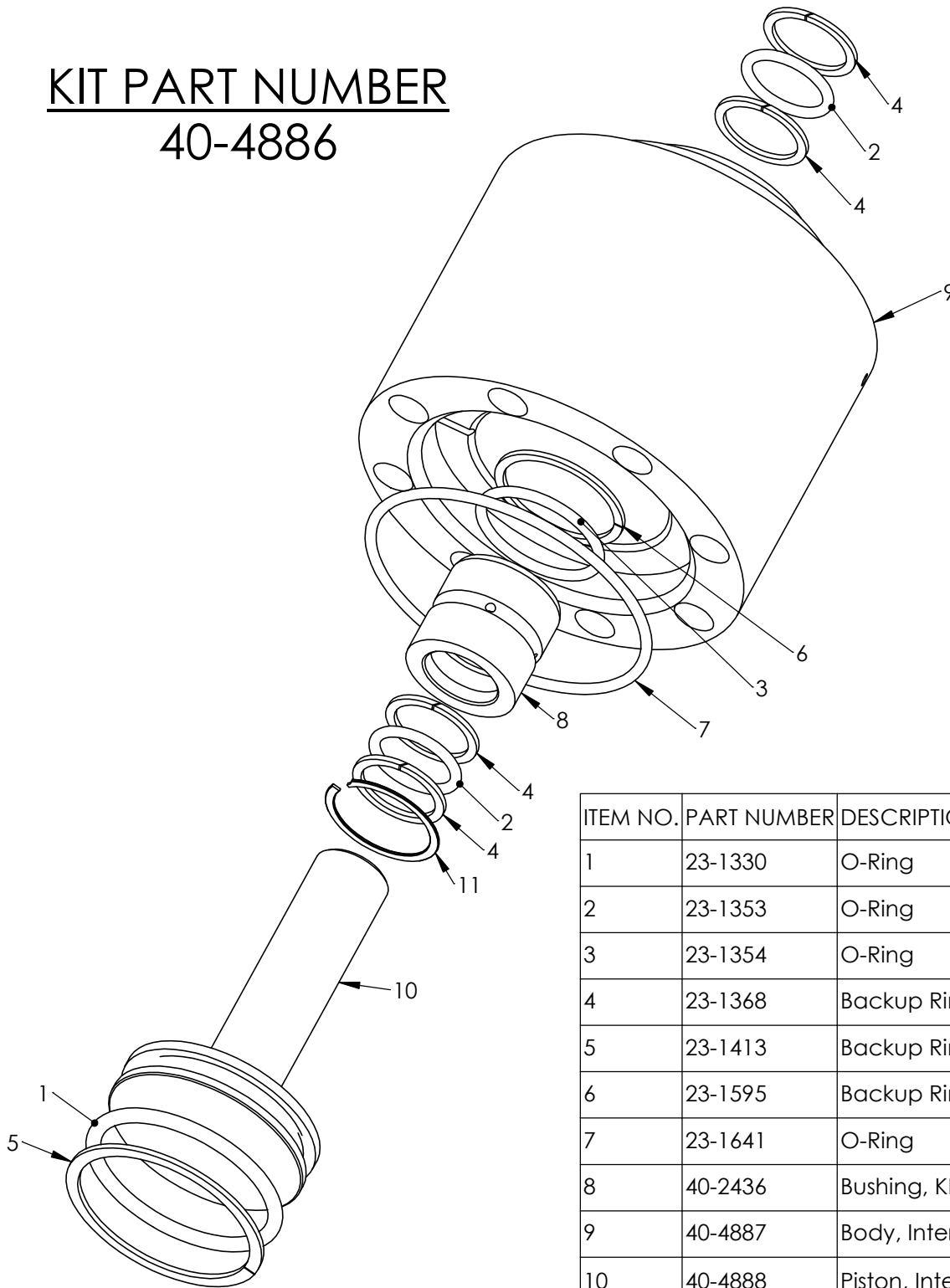

ITEM NO.	PART NUMBER	DESCRIPTION	QTY.
1	23-1330	O-Ring	1
2	23-1353	O-Ring	2
3	23-1354	O-Ring	1
4	23-1368	Backup Ring	4
5	23-1413	Backup Ring	1
6	23-1595	Backup Ring	1
7	23-1641	O-Ring	1
8	40-2436	Bushing, KR-75/140 Int Override	1
9	40-4887	Body, Internal Override	1
10	40-4888	Piston, Internal Override	1
11	50-0409	Retaining Ring	1



**PROPRIETARY AND CONFIDENTIAL**  
THE INFORMATION CONTAINED IN THIS DRAWING IS THE SOLE PROPERTY OF PacSeal. ANY REPRODUCTION IN PART OR AS A WHOLE WITHOUT THE WRITTEN PERMISSION OF PacSeal IS PROHIBITED.

**TITLE Internal Override Bypass Direct Operation Assembly Drawing**

SIZE <b>A</b>	REV <b>7</b>
SHEET 23 OF 26	

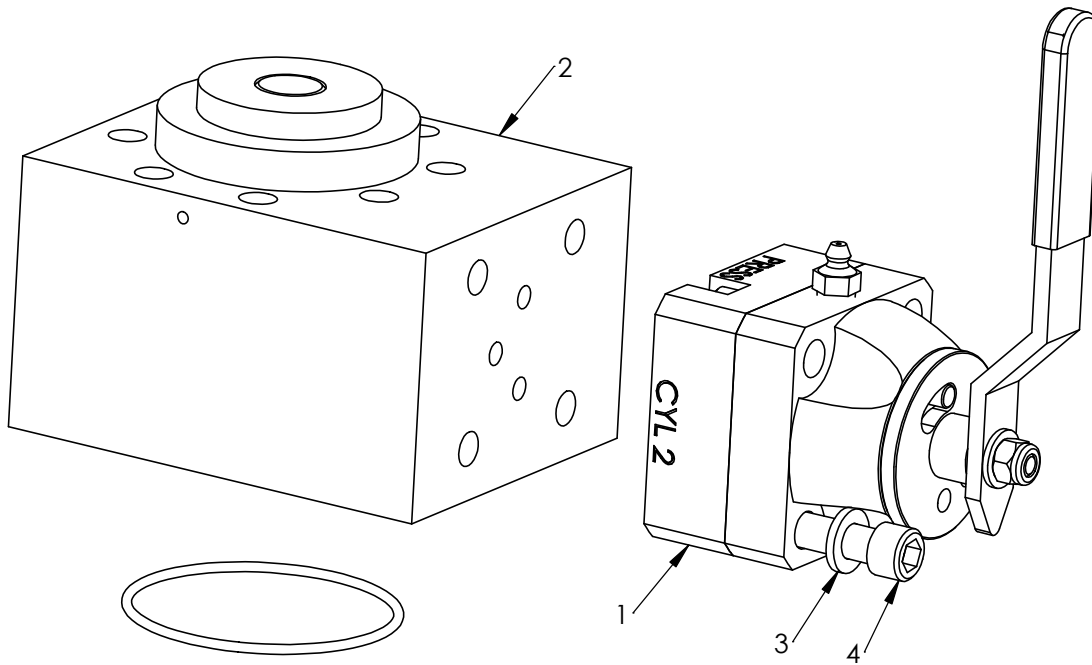

KIT PART NUMBER  
40-4899

ITEM NO.	PART NUMBER	DESCRIPTION	QTY.
1	40-3301	SV-25 Open Center	1
2	40-4895	Internal Override, KR-75/140/150/200	1
3	50-0103	Lock Washer	4
4	50-0338	SHCS	4



**PROPRIETARY AND CONFIDENTIAL**  
THE INFORMATION CONTAINED IN THIS DRAWING IS THE SOLE PROPERTY OF PacSeal. ANY REPRODUCTION IN PART OR AS A WHOLE WITHOUT THE WRITTEN PERMISSION OF PacSeal IS PROHIBITED.

TITLE  
**Internal Override  
Bypass w/ SV-25  
Assembly Drawing**

SIZE <b>A</b>	REV <b>7</b>
------------------	-----------------

**KIT PART NUMBER**  
**40-4894**

ITEM NO.	PART NUMBER	DESCRIPTION	QTY.
1	40-4549	SVx-25 Open Center, 2-Pos 45° CW	1
2	40-4895	Internal Override, KR-75/140/150/200	1
3	50-0103	Lock Washer	4
4	50-0291	Bolt	4

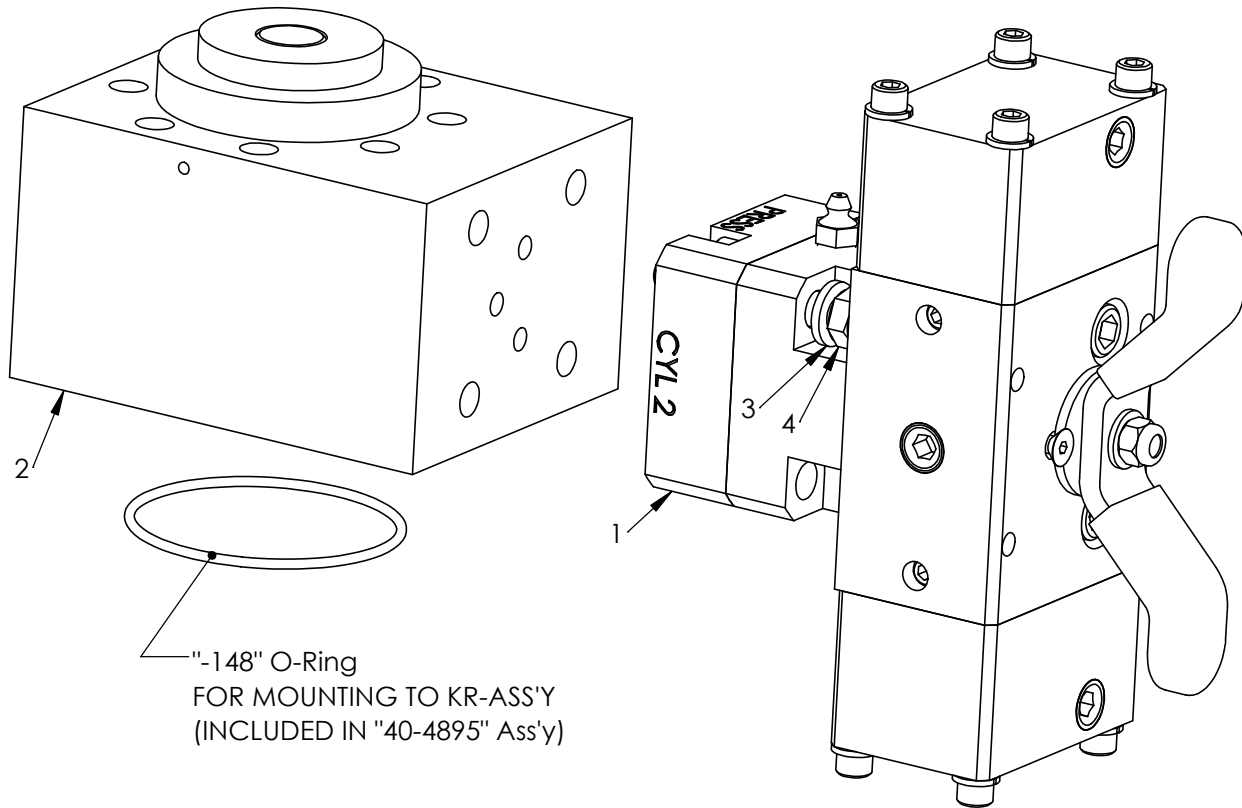

**PROPRIETARY AND CONFIDENTIAL**  
 THE INFORMATION CONTAINED IN THIS DRAWING IS THE SOLE PROPERTY OF PacSeal. ANY REPRODUCTION IN PART OR AS A WHOLE WITHOUT THE WRITTEN PERMISSION OF PacSeal IS PROHIBITED.

TITLE  
**Internal Override Bypass w/ SVx-25 Assembly Drawing**

SIZE <b>A</b>	REV <b>7</b>
SHEET 25 OF 26	

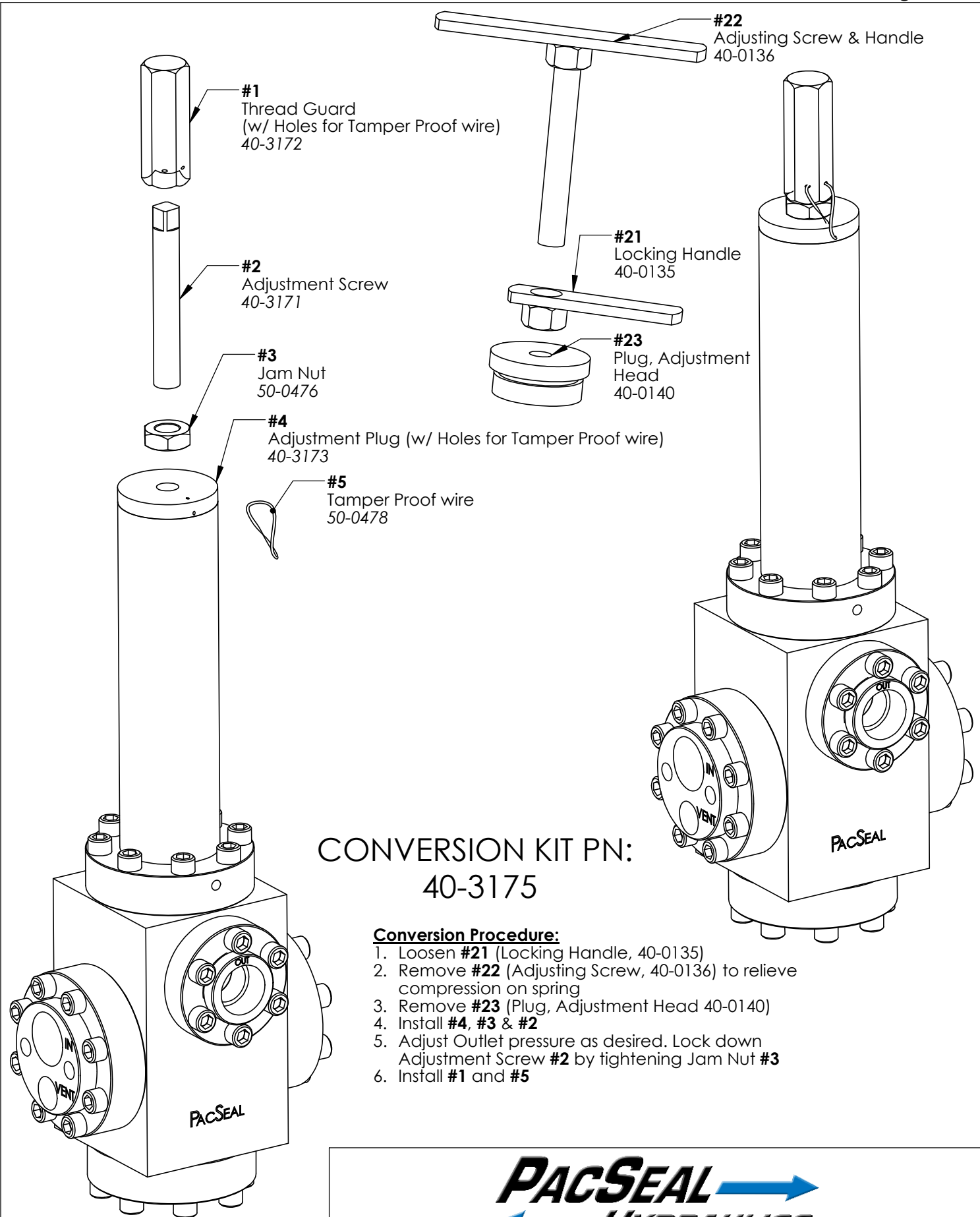

CONVERSION KIT PN:  
40-3175

**Conversion Procedure:**

1. Loosen **#21** (Locking Handle, 40-0135)
2. Remove **#22** (Adjusting Screw, 40-0136) to relieve compression on spring
3. Remove **#23** (Plug, Adjustment Head 40-0140)
4. Install **#4**, **#3** & **#2**
5. Adjust Outlet pressure as desired. Lock down Adjustment Screw **#2** by tightening Jam Nut **#3**
6. Install **#1** and **#5**



**PROPRIETARY AND CONFIDENTIAL**  
THE INFORMATION CONTAINED IN THIS DRAWING IS THE SOLE PROPERTY OF PacSeal.  
ANY REPRODUCTION IN PART OR AS A WHOLE WITHOUT THE WRITTEN PERMISSION OF PacSeal IS PROHIBITED.

TITLE  
**Tamper Proof Conversion Kit**

SIZE <b>A</b>	REV <b>7</b>
SHEET 26 OF 26	