



KR-150 Regulator Specifications **Table of Contents**

2. Specifications and Data Sheet
3. System Integration Guidelines
4. Configuration Overview
5. Regulator with Manual Operator Installation Drawing
6. Regulator with Failsafe Air Operator Installation Drawing
7. Regulator with Failsafe Hydraulic Operator Installation Drawing
8. Regulator with Hydraulic Pilot Operator Installation Drawing
9. High Pressure Output Regulator with Manual Operator Installation Drawing
10. High Pressure Output Regulator with High Torque Failsafe Air Operator Installation Drawing
11. High Pressure Output Regulator with Failsafe Hydraulic Operator Installation Drawing
12. Internal Override Bypass Options Installation Drawing
13. General Assembly Overview
14. L and H Model Configurations Assembly Drawing
15. D and W Model Configurations Assembly Drawing
16. P Model Configuration Assembly Drawing
17. Failsafe Air and Hydraulic Operators Assembly Drawing
18. High Pressure Output Adjustment Head Assembly Drawing
19. High Pressure Output Manual Operator Assembly Drawing
20. High Pressure Output Failsafe Air Operator Assembly Drawing
21. High Pressure Output Failsafe Hydraulic Operator Assembly Drawing
22. Internal Override Bypass Direct Operation Assembly Drawing
23. Internal Override Bypass with SV-25 Assembly Drawing
24. Internal Override Bypass with SVx-25 Assembly Drawing
25. Tamper Proof Conversion Kit Instructions



All PacSeal Hydraulics' KR Pressure Regulators are designed with ShearFlo® metal-to-metal sealing technology.

ShearFlo® sealing technology features:

- High cycle life and anti-wear design is suitable for critical service applications, including contaminated fluids.
- Leak proof, contaminant resistant metal-to-metal seal is accomplished by lapping and polishing hardened stainless steel sealing elements to exacting standards of finish and flatness.
- The sealing elements are spring preloaded and pressure energized, which maintains contact between the two sealing surfaces at all times.

All KR Regulators are tested to PacSeal's strict quality control standards to ensure proper function and reliability. Every ShearFlo® sealing component in a repair kit is inspected to ensure trouble-free performance after field maintenance and repair.

PacSeal Hydraulics' KR Pressure Regulators serve as pressure reducing and regulating valves to maintain system pressure at a desired value (set pressure) which is below that of the supply pressure.

The operator controls the outlet pressure by modulating the compression of springs that act on a pressurized piston. This in turn balances the hydraulic load inside the body. The operator options are as follows:

- Manual
- Failsafe Air Motor with Manual Override
- Failsafe Hydraulic Motor with Manual Override
- Hydraulic Pilot

The internal override bypass operator provides a lean solution for tight space applications by allowing full accumulator pressure to be supplied downstream of the regulator without a dedicated 4-way bypass valve in the hydraulic circuit.

General Specifications	
Supply Port Size	1 in. NPT or SAE (2X)
Outlet Port Size	1-1/2 in. NPT or SAE
Vent Port Size	1 in. NPT or SAE (2X)
Working Pressure Options (Liquid)	3000, 5000, or 6000 psi
Regulated Outlet Pressure Options	See Product Configurator
Cv Factor Outlet	27
Cv Factor Vent	4.1
Rated Flow	250 GPM
Temperature Rating (Regulators and Failsafe Air Motors)	-40° to 250°F
Fluid Media	Hydraulic oil or lubricated water ¹
Weight	See installation drawings
Materials	
ShearFlo Sealing Components (i.e. Rotor and Seal Rings)	Hardened stainless steel ¹
Body	Stainless steel
Flanges and Operators	Coated carbon steel
Hardware	Coated carbon steel
O-rings	Buna-N (N), Viton (V), or EPR (E)
Backup Rings	Teflon

¹For water based media, special alloy seal rings may be required for optimum performance and durability - Contact PacSeal for details.

Model	Supply Pressure [psi]	Regulated Outlet Pressure [psi]	Deadband Range [psi]*
L	3000/5000	300-1800	100-150
D	5000/6000	500-3000	200-300
H	5000/6000	500-3300	100-150
W	6000	700-4500	200-300
P	3000/5000/6000	50-6000	0-100

*Deadband is the difference between the set pressure and the actual outlet pressure that triggers the KR to open or vent. The deadband will vary depending on factors that influence the friction between the seal rings and flow plates, such as: type of fluid and lubricity properties, temperature, differential pressure between supply and regulated outlet, seal ring and flow plate wear condition, and lastly interpretation influenced by gauge sensitivity. The Reset Range or Hysteresis is within +/- 150 psi for all models.



Circuit Design Considerations

The KR-150, -175, and -200 regulators are subject to hammering if the outlet flow is restricted or not adequate to match the inlet flow rate. To prevent hammering, the downstream hydraulic circuit must have adequate flow; such that the pipe/hose diameter matches or is greater than that of the KR-150 outlet, there are little to no restrictions after the outlet (minimize bends, no check valves, no ball valves, etc.). To safeguard this further, an accumulator is recommended to be used just downstream, in close proximity to the regulator's outlet. See circuit schematic example, below.

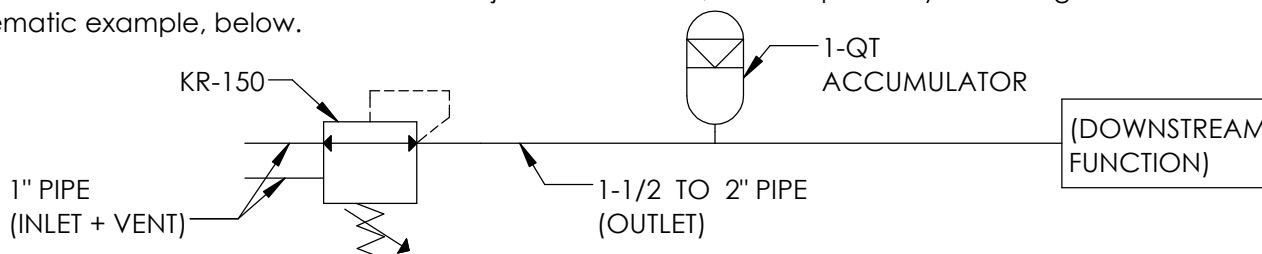

System Start-up

Upon system start-up, there must be load on the pressure regulator piston to prevent hammering/shock that may damage the KR.

- For KR regulators with a manual operator, the top of the manual adjustment handle must be about 2-3/4 inches from the top of the adjustment head.
- For KR regulators with failsafe air/hydraulic remote operators, the top of the manual adjustment handle must be about 4-1/4 inches from the top of the adjustment head.
- For KR regulators with hydraulic pilot operators, there should be about 1500 psi (500 psi minimum) supplied to the pilot inlet.

Rated Regulated Outlet Pressure

KR pressure regulators are rated to output a regulated pressure range that is tested and verified prior to shipment. Operating at a pressure outside of this range is possible, but may diminish as the KR wears during service. 0 psi can be achieved by completely unloading the pressure adjustment (decompressing spring to its free state). To match the supply pressure, the pressure adjustment must be completely loaded (compressing springs to solid), which allows the supply pressure to free-flow through the regulator.

NOTE: Although 0 psi is the output, DO NOT attempt to perform maintenance or disassemble any components downstream of the KR while in this state.

To maximize the regulated outlet pressure range, the hydraulic pilot operator is the best option. This operator regulates pressure down to 50 psi and up to the supply pressure.

Set Pressure Adjustment

When the set pressure on a spring operator is being changed or adjusted, the outlet needs to be briefly opened and closed a few times to allow the operator and pressure to stabilize. This can be achieved by operating a manifold control valve or installing a separate, much smaller valve directly on the outlet line near the KR. The control valve should be briefly opened and closed after the KR has been adjusted; this will stabilize the pressure reading. Once satisfied with the set pressure, tighten the locking handle down to the adjustment head.

Avoid Series Installation

It is NOT recommended that KR's be installed in series (e.g. do NOT connect the outlet of one KR to the inlet of another). Doing so may prevent set pressure stabilization.

Pressure Relieving Feature

The KR's are designed to self-relieve (vent) at an over-pressurization condition to maintain the regulated set pressure. Thus, the vent port must always be connected without any restrictions and not joined with any other common returns to the reservoir or tank at ambient pressure (i.e. solo low pressure hydraulic hose or tubing from KR to tank) to ensure proper safety and function.

In the event of a supply seal ring or flow plate failure, the supply pressure will leak into the KR body through the vent seal ring port and then be directed to the reservoir or tank.

Model Code Configurator

Basic Model	Ports	Supply Pressure	Regulated Outlet Pressure		Operator	Water Glycol App's	
			<u>Operating Range²</u>	<u>Deadband</u>			
KR-150	N NPT	3 3000 psi	L 300-1800 psi	100-150 psi	M Manual	-IO Direct	-W ¹ Special Alloy
	S SAE	5 5000 psi			FSA Failsafe Air Motor	-IS with SV-	Seal Rings
	C Code-61 ¹	5 5000 psi	D 500-3000 psi	200-300 psi	FSH Failsafe Hydraulic	-IX with SVx-	
	D Code-62 ¹	6 6000 psi	H 500-3300 psi	100-150 psi			
		6 6000 psi	W 700-4500 psi	200-300 psi			
	3, 5, or 6	P ³ 50-6000 psi	0-100 psi	H Hydraulic Pilot			

Notes: ¹ Not a standard option - special order only

² Regulated Outlet Pressure cannot exceed supply pressure. Absolute Outlet Pressure is 0 psi up to 25% above the maximum operating pressure.

³ Maximum regulated outlet pressure matches the supply pressure for a regulator with the Hydraulic Pilot operator

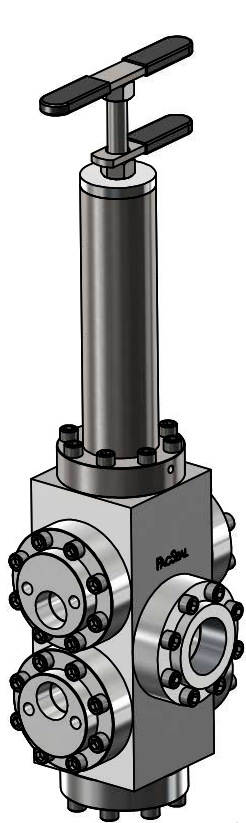

KR-150 Regulator with Manual Operator
Example: KR-150N3LM

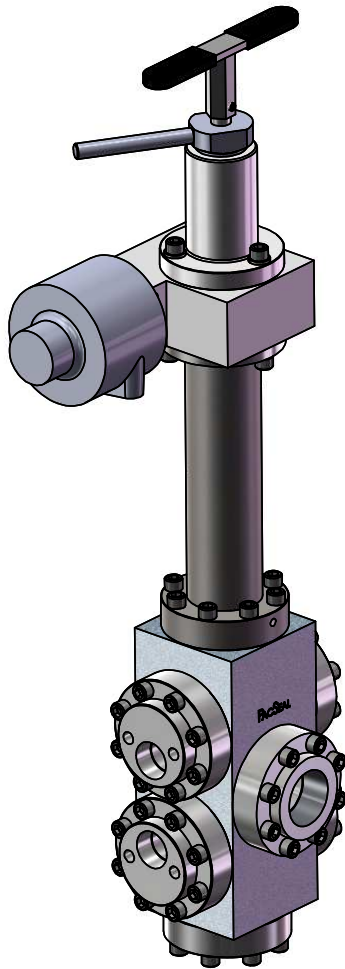

KR-150 Regulator with Failsafe Air Motor Operator

Example: KR-150S5DFSA

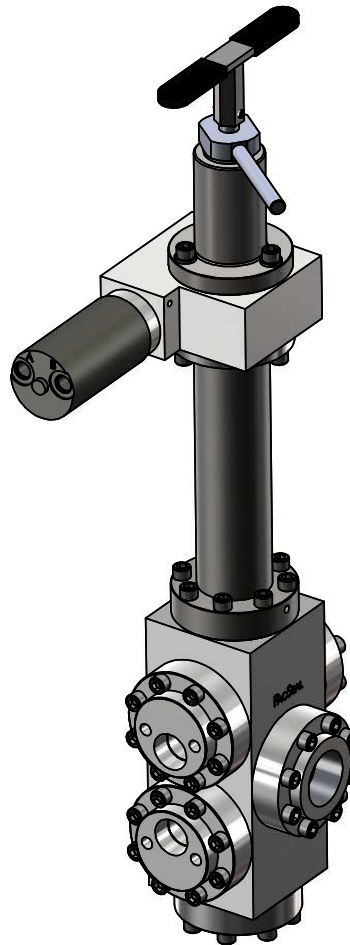

KR-150 Regulator with Failsafe Hydraulic Motor Operator

Example: KR-150S6HFSH

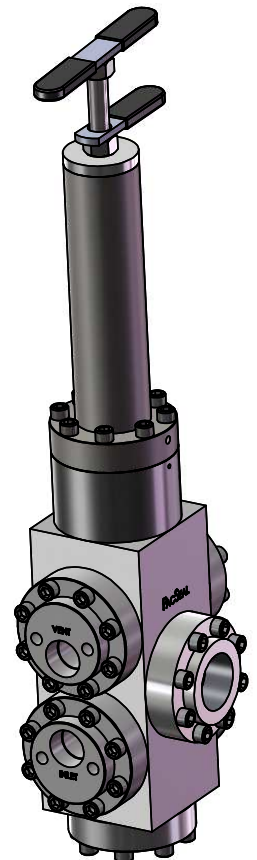

KR-150 Regulator with Direct Internal Override

Example: KR-150N5DM-IO

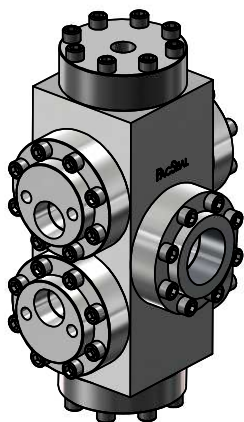

Hydraulic Pilot Operator
Example: KR-150S3PH

NOTES:

1. Displayed models are just a few examples of the many potential configurations



PROPRIETARY AND CONFIDENTIAL

THE INFORMATION CONTAINED IN THIS DRAWING IS THE SOLE PROPERTY OF PacSeal. ANY REPRODUCTION IN PART OR AS A WHOLE WITHOUT THE WRITTEN PERMISSION OF PacSeal IS PROHIBITED.

TITLE

Configuration Overview

SIZE

A

REV

8

SHEET 4 OF 25

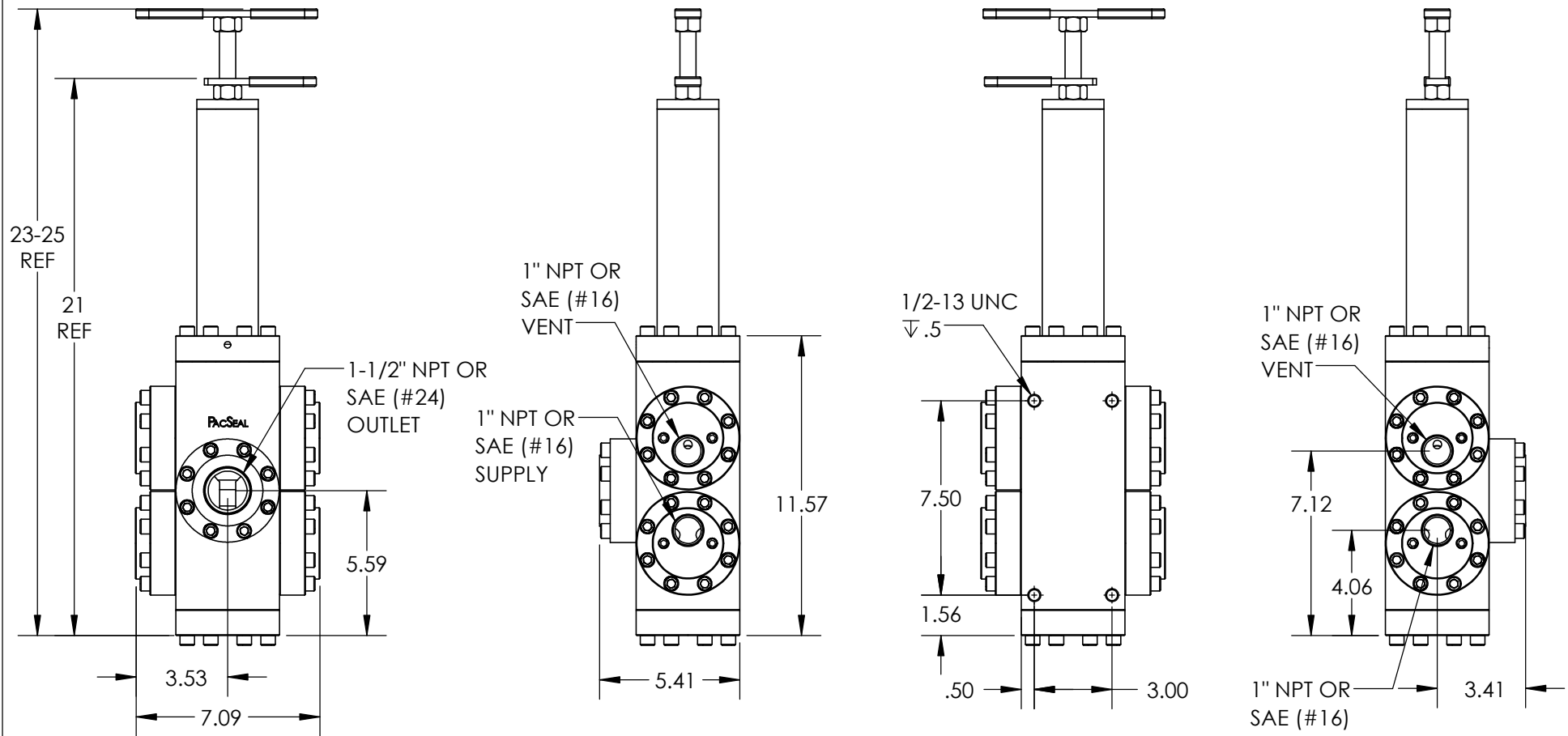

Notes:

1. Adjustment handle can be threaded in or out to increase or decrease compression on the spring and thus on the regulated outlet pressure.
2. Model configuration (Regulated Outlet Pressure) options: L, D
3. Weight - 72 lb.
4. All dimensions are consistent for KR-150 NPT or SAE ORB porting options, regardless of supply/outlet pressure and operator selection.

<p>PROPRIETARY AND CONFIDENTIAL</p> <p>THE INFORMATION CONTAINED IN THIS DRAWING IS THE SOLE PROPERTY OF PacSeal. ANY REPRODUCTION IN PART OR AS A WHOLE WITHOUT THE WRITTEN PERMISSION OF PacSeal Hydraulics IS PROHIBITED.</p>	<p>TITLE</p> <p>Regulator w/ Manual Operator (NPT/SAE) Installation Drawing</p>	<p>SIZE</p> <p>A</p>	<p>REV</p> <p>8</p>
			<p>SHEET 5 OF 25</p>

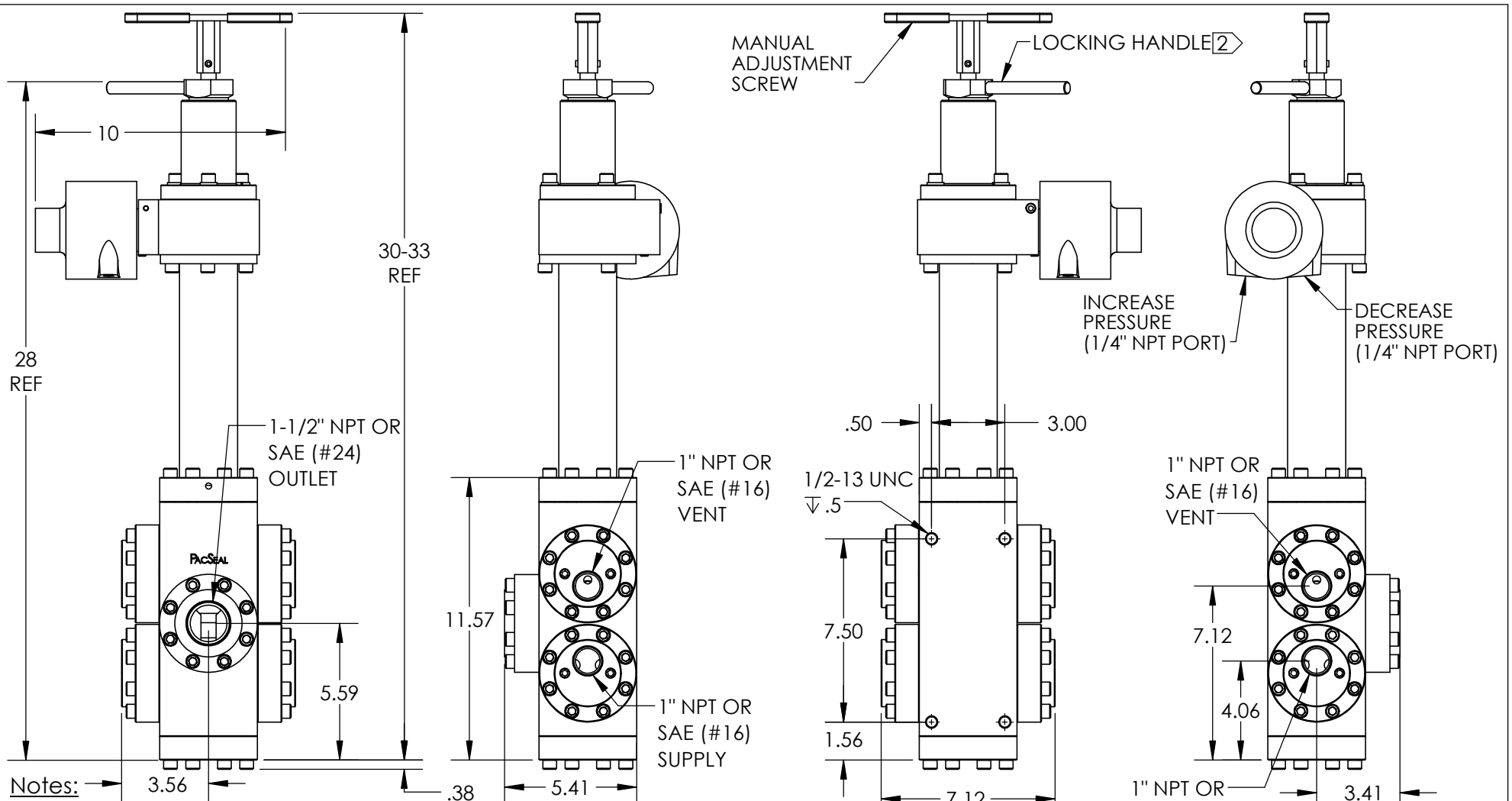

Notes:

1. Failsafe Air Motor provides remote operation with a manual override. Upon loss of pilot signal, there is no loss of regulated outlet pressure.
- ② Turn locking handle clockwise to lock for failsafe remote operation. Turn locking handle counter-clockwise to unlock for manual operation/override.
3. Recommended Air Supply - 115 psi max with 1/2" tubing.
4. Model configuration (Regulated Outlet Pressure) options: L, D
5. Weight - 100 lb.
6. All dimensions are consistent for KR-150 NPT or SAE ORB porting options, regardless of supply/outlet pressure and operator selection.

			
<p style="text-align: center;">PROPRIETARY AND CONFIDENTIAL</p> <p>THE INFORMATION CONTAINED IN THIS DRAWING IS THE SOLE PROPERTY OF PacSeal. ANY REPRODUCTION IN PART OR AS A WHOLE WITHOUT THE WRITTEN PERMISSION OF PacSeal Hydraulics IS PROHIBITED.</p>	<p>TITLE Regulator w/ Failsafe Air Operator (NPT/SAE) Installation Drawing</p>	<p>SIZE A</p>	<p>REV 8</p>
		<p>SHEET 6 OF 25</p>	

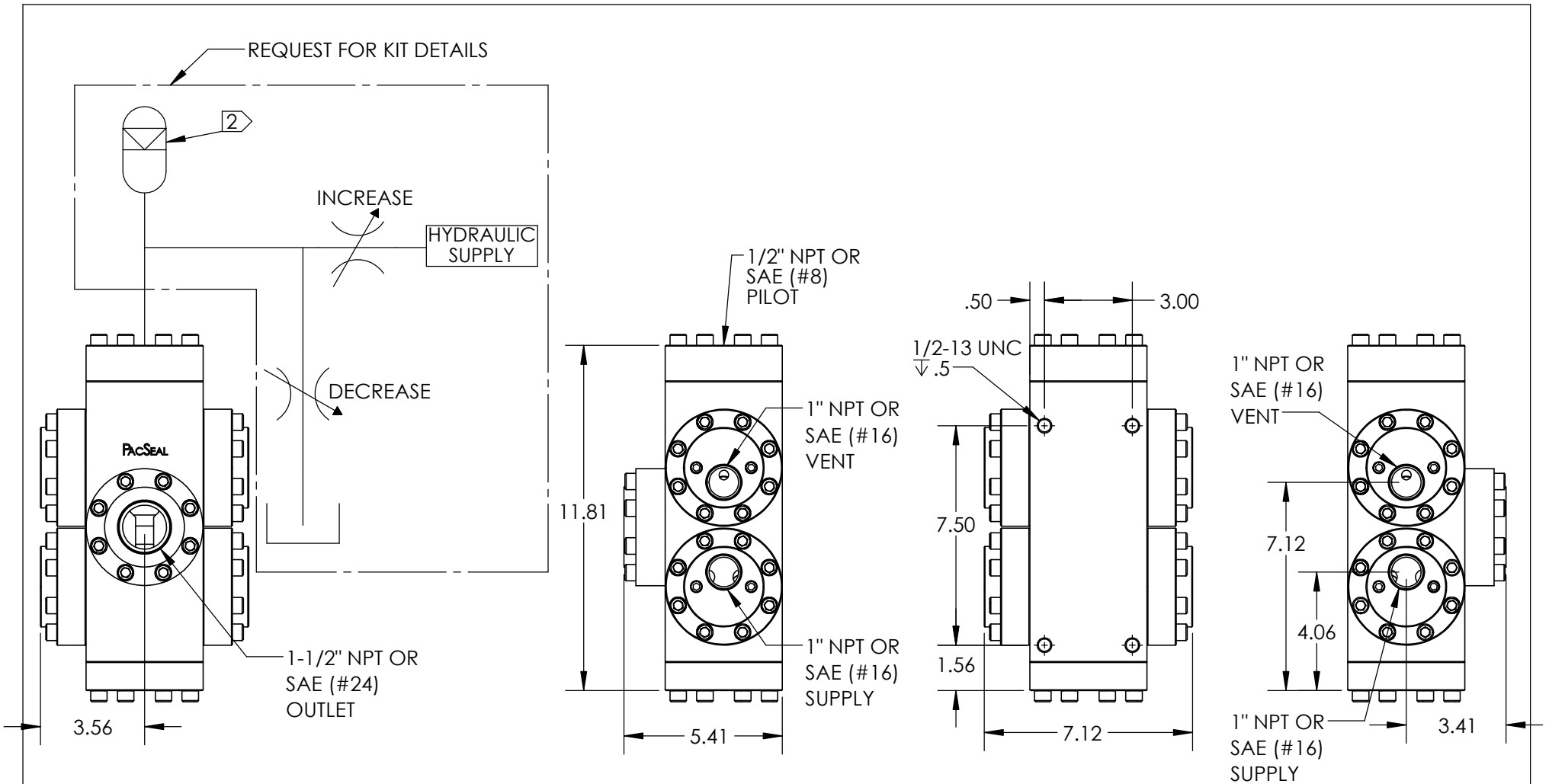

Notes:

1. A remote, variable hydraulic signal operates on a piston with a 1:1 ratio which allows for the most precisely controlled outlet pressures of all options. Loss of hydraulic pilot pressure will result in the outlet venting to tank.
- ② Requires a minimum 1 Pint Accumulator for operation
3. Model configuration (Regulated Outlet Pressure) option: P
4. Weight - 61 lb.
5. All dimensions are consistent for KR-150 NPT or SAE porting options, regardless of supply/outlet pressure and operator selection.



PROPRIETARY AND CONFIDENTIAL
 THE INFORMATION CONTAINED IN THIS DRAWING IS THE SOLE PROPERTY OF PacSeal. ANY REPRODUCTION IN PART OR AS A WHOLE WITHOUT THE WRITTEN PERMISSION OF PacSeal IS PROHIBITED.

TITLE
Regulator w/ Hydraulic Pilot Operator (NPT/SAE) Installation Drawing

SIZE A	REV 8
SHEET 8 OF 25	

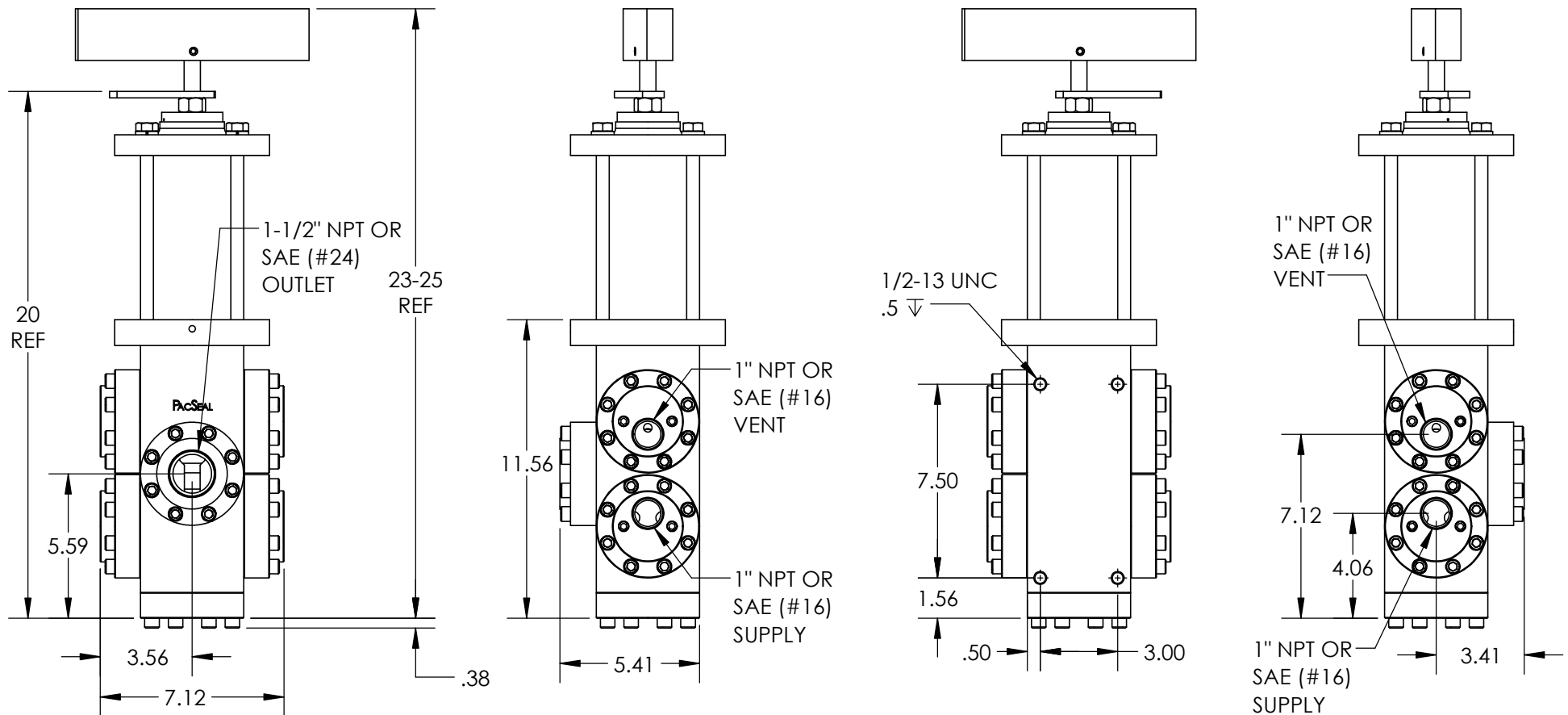

Notes:

1. Adjustment handle can be threaded in or out to increase or decrease compression on the spring and thus on the regulated outlet pressure.
2. Model configuration (Regulated Outlet Pressure) options: H (5000 psi supply) and W (6000 psi supply)
3. Weight - 96 lb.
4. All dimensions are consistent for KR-150 NPT or SAE ORB porting options, regardless of supply/outlet pressure and operator selection.

					
<p style="text-align: center;">PROPRIETARY AND CONFIDENTIAL</p> <p style="font-size: small;">THE INFORMATION CONTAINED IN THIS DRAWING IS THE SOLE PROPERTY OF PacSeal. ANY REPRODUCTION IN PART OR AS A WHOLE WITHOUT THE WRITTEN PERMISSION OF PacSeal IS PROHIBITED.</p>	<p style="text-align: center;">TITLE High Pressure Output w/ Manual Operator</p>				
	<table border="1" style="border-collapse: collapse;"> <tr> <td style="padding: 2px;">SIZE A</td> <td style="padding: 2px;">REV 8</td> </tr> <tr> <td colspan="2" style="text-align: center; padding: 2px;">SHEET 9 OF 25</td> </tr> </table>	SIZE A	REV 8	SHEET 9 OF 25	
SIZE A	REV 8				
SHEET 9 OF 25					

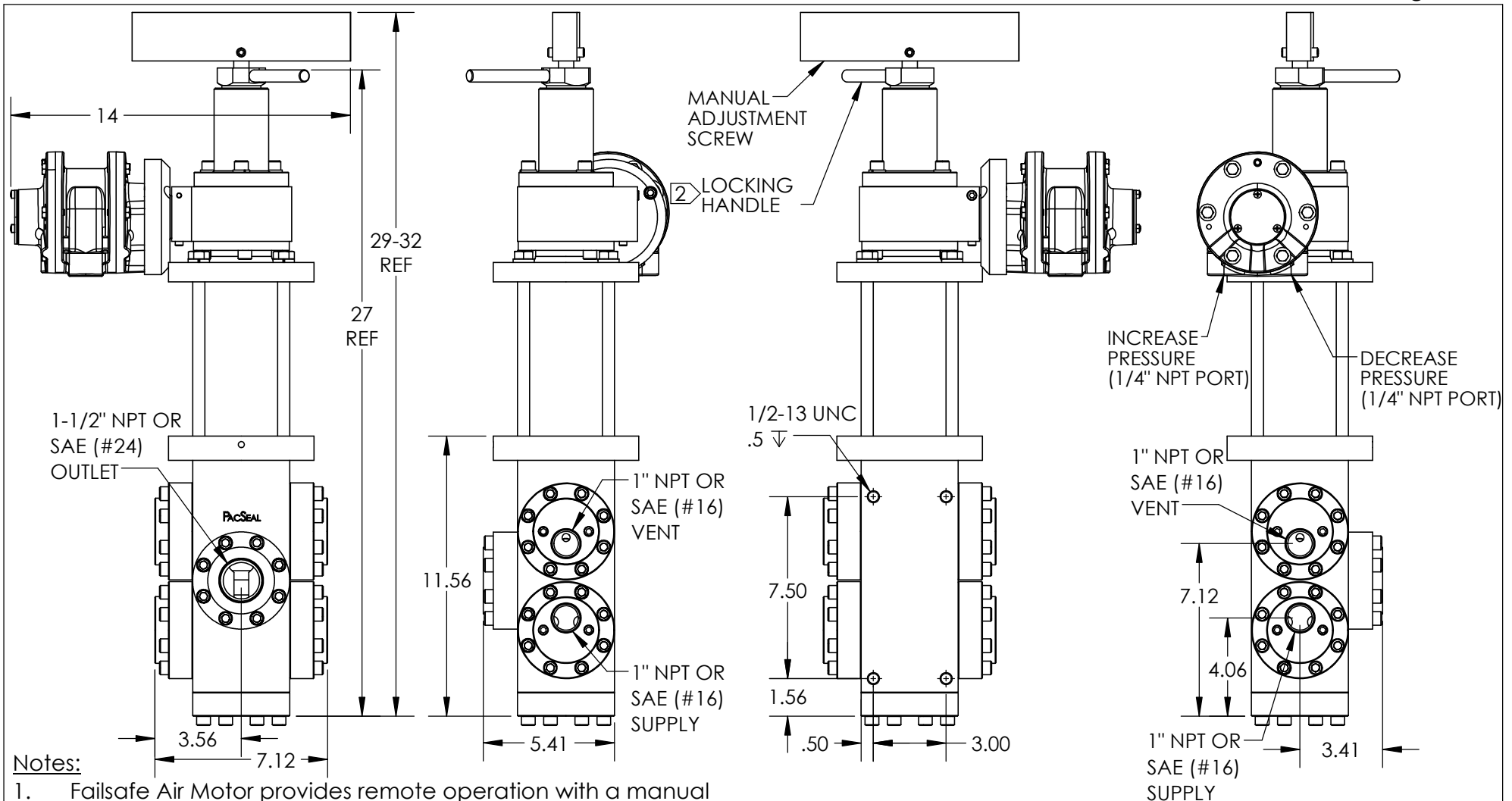

Notes:

1. Failsafe Air Motor provides remote operation with a manual override. Upon loss of pilot signal, there is no loss of regulated outlet pressure.
- ② Turn locking handle clockwise to lock for failsafe remote operation. Turn locking handle counter-clockwise to unlock for manual operation/override.
3. Recommended air supply - 115 psi max w/ 1/2" tubing.
4. Model configuration (Regulated Outlet Pressure) option: H (5000/6000 psi supply) and W (6000 psi supply)
5. Weight - 141 lb.
6. All dimensions are consistent for KR-150 NPT or SAE ORB porting options, regardless of supply/outlet pressure and operator selection.

			
<p style="text-align: center; font-weight: bold; font-size: small;">PROPRIETARY AND CONFIDENTIAL</p> <p style="font-size: x-small;">THE INFORMATION CONTAINED IN THIS DRAWING IS THE SOLE PROPERTY OF PacSeal. ANY REPRODUCTION IN PART OR AS A WHOLE WITHOUT THE WRITTEN PERMISSION OF PacSeal Hydraulics IS PROHIBITED.</p>	<p style="font-weight: bold;">TITLE</p> <p style="font-weight: bold;">High Pressure Output Regulator w/ High Torque Failsafe Air Operator</p>	<p>SIZE</p> <p style="font-size: 2em; font-weight: bold;">A</p>	<p>REV</p> <p style="font-size: 2em; font-weight: bold;">8</p>
			SHEET 10 OF 25

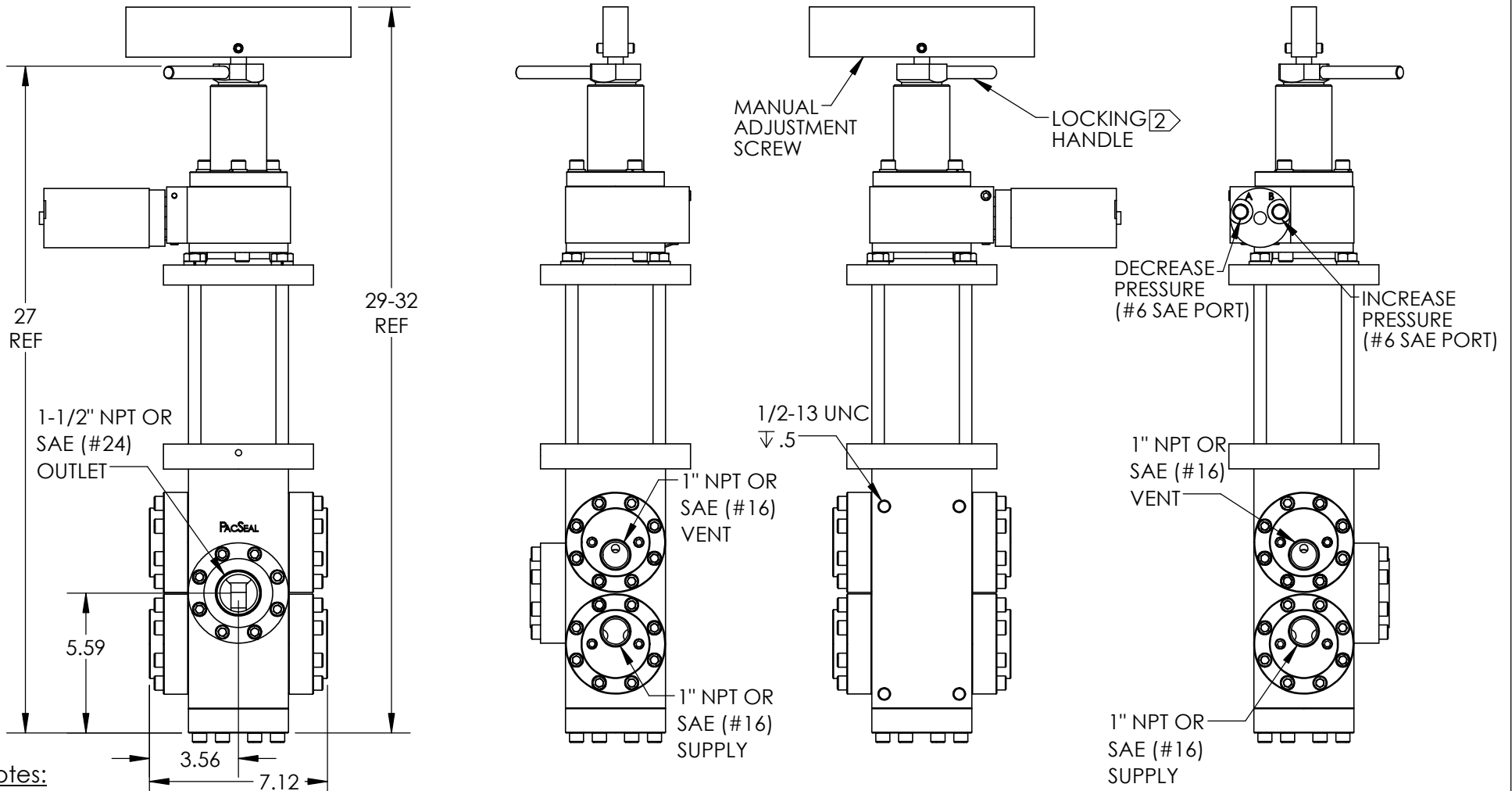

Notes:

1. Failsafe Hydraulic Motor provides remote operation with a manual override. Upon loss of pilot signal, there is no loss of regulated outlet pressure.
2. Turn locking handle clockwise to lock for failsafe remote operation. Turn locking handle counter-clockwise to unlock for manual operation/override.
3. Max Hydraulic Motor Supply Pressure - 1500 psi
4. Model configuration (Regulated Outlet Pressure) option: H (5000/6000 psi supply) and W (6000 psi supply).
5. Weight - 116 lb.
6. All dimensions are consistent for KR-150 NPT or SAE ORB porting options, regardless of supply/outlet pressure and operator selection.



PROPRIETARY AND CONFIDENTIAL

THE INFORMATION CONTAINED IN THIS DRAWING IS THE SOLE PROPERTY OF PacSeal. ANY REPRODUCTION IN PART OR AS A WHOLE WITHOUT THE WRITTEN PERMISSION OF PacSeal IS PROHIBITED.

TITLE

High Pressure Output Regulator w/ Failsafe Hydraulic Operator

SIZE
A

REV
8

SHEET 11 OF 25

Notes:

1. The listed components vary based on Supply and Regulated Outlet Pressures, while all other regulator components (shown in sheet 12 "General Assembly Overview") are shared.

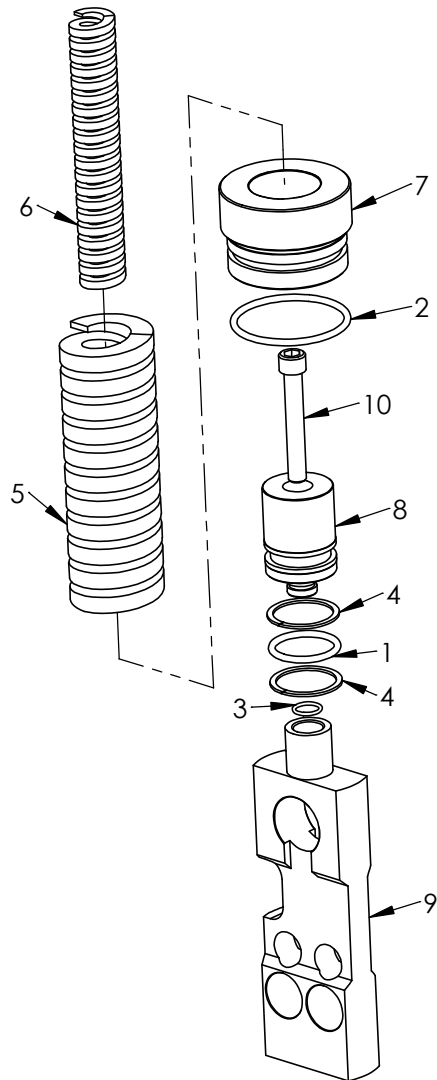

KR-150 L Regulator

ITEM NO.	PART NUMBER	DESCRIPTION	QTY.
1	23-1124	O-Ring	1
2	23-1319	O-Ring	1
3	23-1333	O-Ring	1
4	23-1342	Backup Ring	2
5	40-0143	Spring, Outer	1
6	40-0144	Spring, Inner	1
7	40-1351	Piston Guide, L	1
8	40-1352	Piston, L	1
9	40-0714	Seal Container	1
10	50-0331	Screw	1

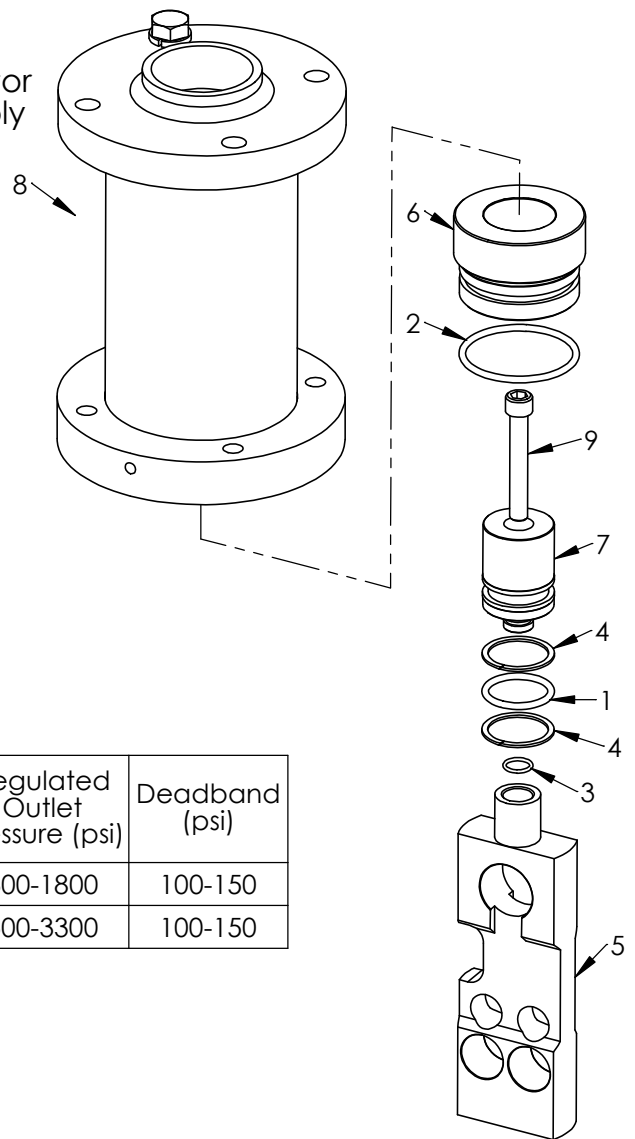

KR-150 H Regulator
With High Pressure Output Adjustment Head

Model	Supply Pressure (psi)	Regulated Outlet Pressure (psi)	Deadband (psi)
L	3000/5000	300-1800	100-150
H	5000/6000	500-3300	100-150

ITEM NO.	PART NUMBER	DESCRIPTION	QTY.
1	23-1124	O-Ring	1
2	23-1319	O-Ring	1
3	23-1333	O-Ring	1
4	23-1342	Backup Ring	2
5	40-0714	Seal Container	1
6	40-1351	Piston Guide, L	1
7	40-1352	Piston, L	1
8	40-2927	KR-75/140/150 L-HP Manual Operator	1
9	50-0331	Screw	1



PROPRIETARY AND CONFIDENTIAL
THE INFORMATION CONTAINED IN THIS DRAWING IS THE SOLE PROPERTY OF PacSeal. ANY REPRODUCTION IN PART OR AS A WHOLE WITHOUT THE WRITTEN PERMISSION OF PacSeal IS PROHIBITED.

TITLE
L and H Model Configurations Assembly Drawing

SIZE
A

REV
8

Notes:

1. The listed components vary based on Supply and Regulated Outlet Pressures, while all other regulator components (shown in sheet 12 "General Assembly Overview") are shared.

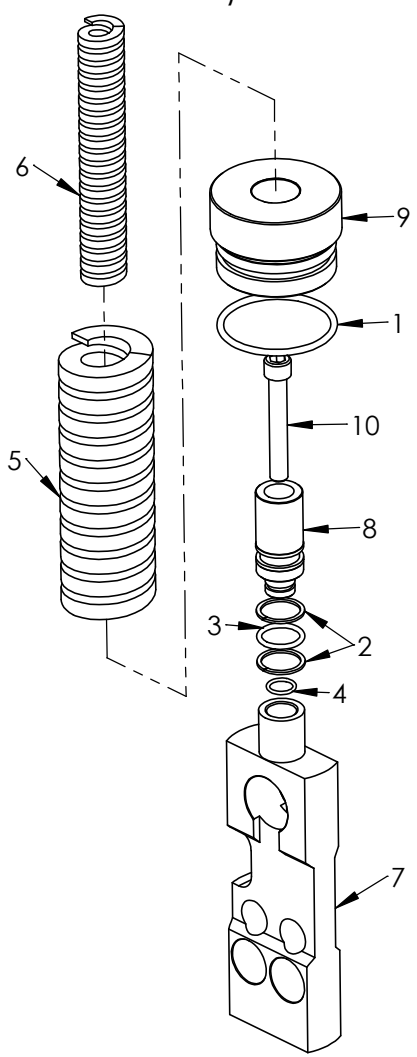

KR-150 D Regulator

ITEM NO.	PART NUMBER	DESCRIPTION	QTY.
1	23-1319	O-Ring	1
2	23-1331	Backup Ring	2
3	23-1332	O-Ring	1
4	23-1333	O-Ring	1
5	40-0143	Spring, Outer	1
6	40-0144	Spring, Inner	1
7	40-0714	Seal Container	1
8	40-0717	Piston, D	1
9	40-0718	Piston Guide, D	1
10	50-0331	SHCS	1

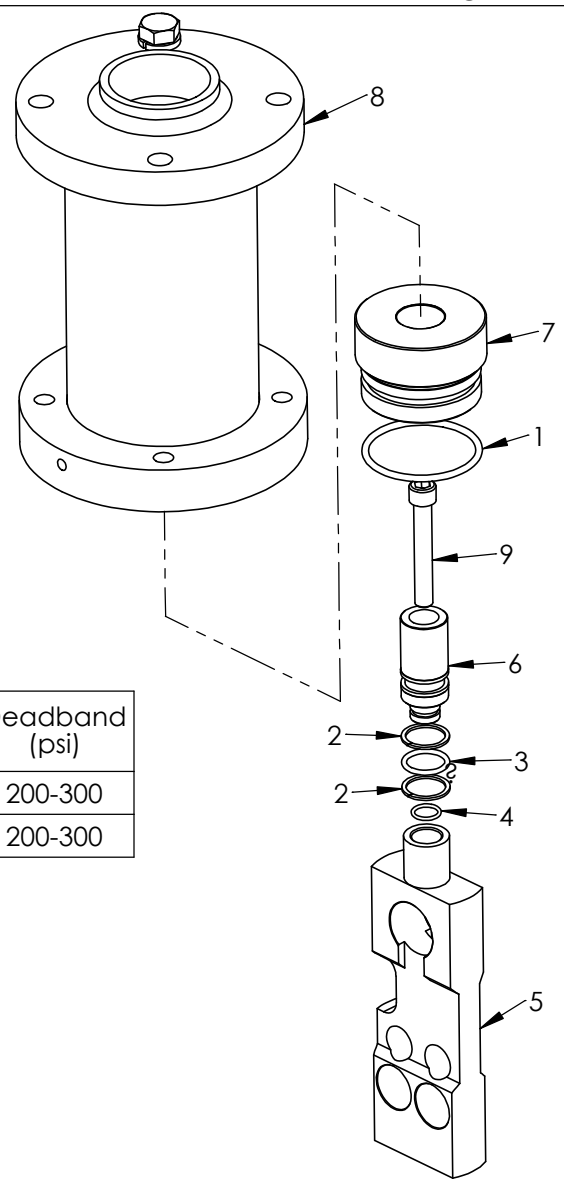

**KR-150 W Regulator
with High Pressure Output
Adjustment Head**

ITEM NO.	PART NUMBER	DESCRIPTION	QTY.
1	23-1319	O-Ring	1
2	23-1331	Backup Ring	2
3	23-1332	O-Ring	1
4	23-1333	O-Ring	1
5	40-0714	Seal Container	1
6	40-0717	Piston, D	1
7	40-0718	Piston Guide, D	1
8	40-2927	High Pressure Output Adj. Head	1
9	50-0331	SHCS	1



PROPRIETARY AND CONFIDENTIAL
THE INFORMATION CONTAINED IN THIS DRAWING IS THE SOLE PROPERTY OF PacSeal. ANY REPRODUCTION IN PART OR AS A WHOLE WITHOUT THE WRITTEN PERMISSION OF PacSeal IS PROHIBITED.

TITLE D and W Model Configurations Assembly Drawing

SIZE A
REV 8
SHEET 15 OF 25

Notes:

- The listed components vary based on Supply and Regulated Outlet Pressures, while all other regulator components (shown in sheet 12 "General Assembly Overview") are shared.

Model	Supply Pressure (psi)	Regulated Outlet Pressure (psi)	Deadband (psi)
P	3000/5000/6000	50-6000	0-100

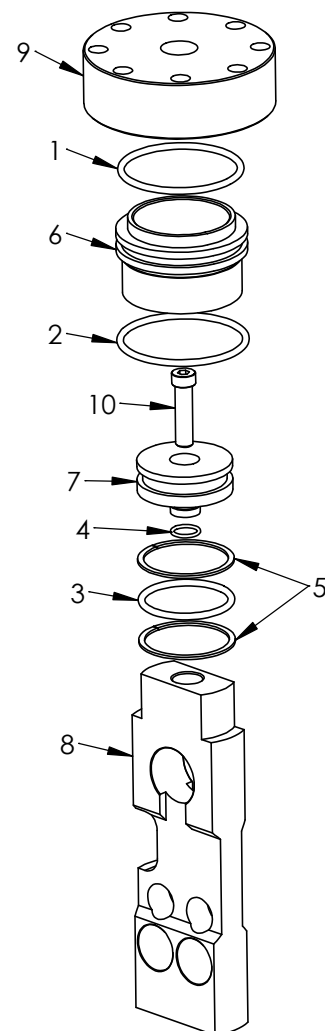

**KR-150 P Regulator
(Hydraulic Pilot)**

ITEM NO.	PART NUMBER	DESCRIPTION	QTY.
1	23-1128	O-Ring	1
2	23-1327	O-Ring	1
3	23-1330	O-Ring	1
4	23-1333	O-Ring	1
5	23-1413	Backup Ring	2
6	40-0318	Piston Guide, KR-150	1
7	40-0319	Piston, Hydraulic	1
8	40-0320	Seal Container	1
9	40-0324	Hydraulic Head	1
10	50-0068	Bolt, SHCS	1



PROPRIETARY AND CONFIDENTIAL
 THE INFORMATION CONTAINED IN THIS DRAWING IS THE SOLE PROPERTY OF PacSeal.
 ANY REPRODUCTION IN PART OR AS A WHOLE WITHOUT THE WRITTEN PERMISSION OF PacSeal IS PROHIBITED.

TITLE **D and P Model Configurations Assembly Drawing**

SIZE **A** **REV** **8**
 SHEET 16 OF 25

ITEM NO.	PART NUMBER	DESCRIPTION	QTY.
1	23-1123	O-Ring	1
2	23-1356	O-Ring	1
3	23-1385	O-Ring	1
4	23-1404	O-Ring	1
5	23-1405	O-Ring	1
6	40-0414	Adapter Plate	1
7	40-0416	Failsafe Collar	1
8	40-0418	Failsafe Handle	1
9	40-0419	Shaft Extension, Failsafe Air	1
10	40-0543	Motor, Failsafe Air Standard	1
11	40-2742	Worm	1
12	40-3960	Fail Safe Shaft, KR	1
13	40-3962	Housing, KR Shaft Adjustment	1
14	40-3964	Failsafe Nut Assy	1
15	40-4978	Failsafe Body	1
16	40-4979	Worm Gear	1
17	50-0072	Screw	6
18	50-0103	Lock Washer	3
19	50-0154	Roll Pin	1
20	50-0156	Screw	1
21	50-0157B	Bearing, NTA-1220	1
22	50-0157T	Thrust Washer, TRB-1220	2
23	50-0158	Roller Bearing	1
24	50-0160	Set Screw	2
25	50-0223	Set Screw	2
26	50-0287	Roll Pin	1
27	50-0483	Roller Bearing	1
28	50-0686	Bearing	1
29	50-0687	Thrust Washer	2

Failsafe Air Operator (40-3963)

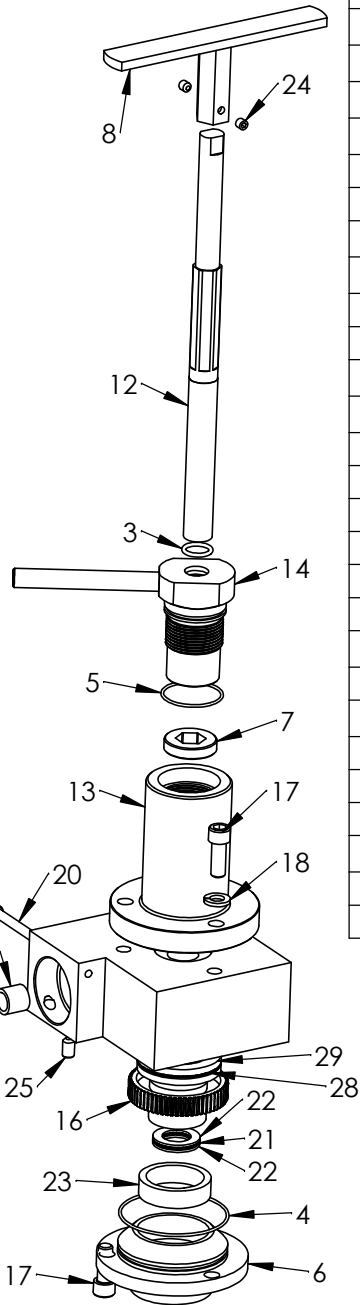

ITEM NO.	PART NUMBER	DESCRIPTION	QTY.
1	23-1123	O-Ring	1
2	23-1356	O-Ring	1
3	23-1385	O-Ring	1
4	23-1404	O-Ring	1
5	23-1405	O-Ring	1
6	40-0414	Adapter Plate	1
7	40-0416	Failsafe Collar	1
8	40-0418	Failsafe Handle	1
9	40-0715	Hydraulic Adapter	1
10	40-0719	Motor, Failsafe Hydraulic	1
11	40-2742	Worm	1
12	40-3960	Failsafe Shaft	1
13	40-3962	Housing, KR Shaft Adjustment	1
14	40-3964	Failsafe Nut Assy	1
15	40-4978	Failsafe Body	1
16	40-4979	Worm Gear	1
17	50-0072	Screw	6
18	50-0103	Lock Washer	3
19	50-0154	Roll Pin	1
20	50-0156	Screw	1
21	50-0157B	Bearing	1
22	50-0157T	Thrust Washer	2
23	50-0158	Roller Bearing	1
24	50-0160	Set Screw	2
25	50-0215	Screw	4
26	50-0223	Set Screw	2
27	50-0483	Roller Bearing	1
28	50-0686	Thrust Bearing, NTA-2435	1
29	50-0687	Thrust Washer, TRF-2435	2

Failsafe Hydraulic Operator (40-4255)

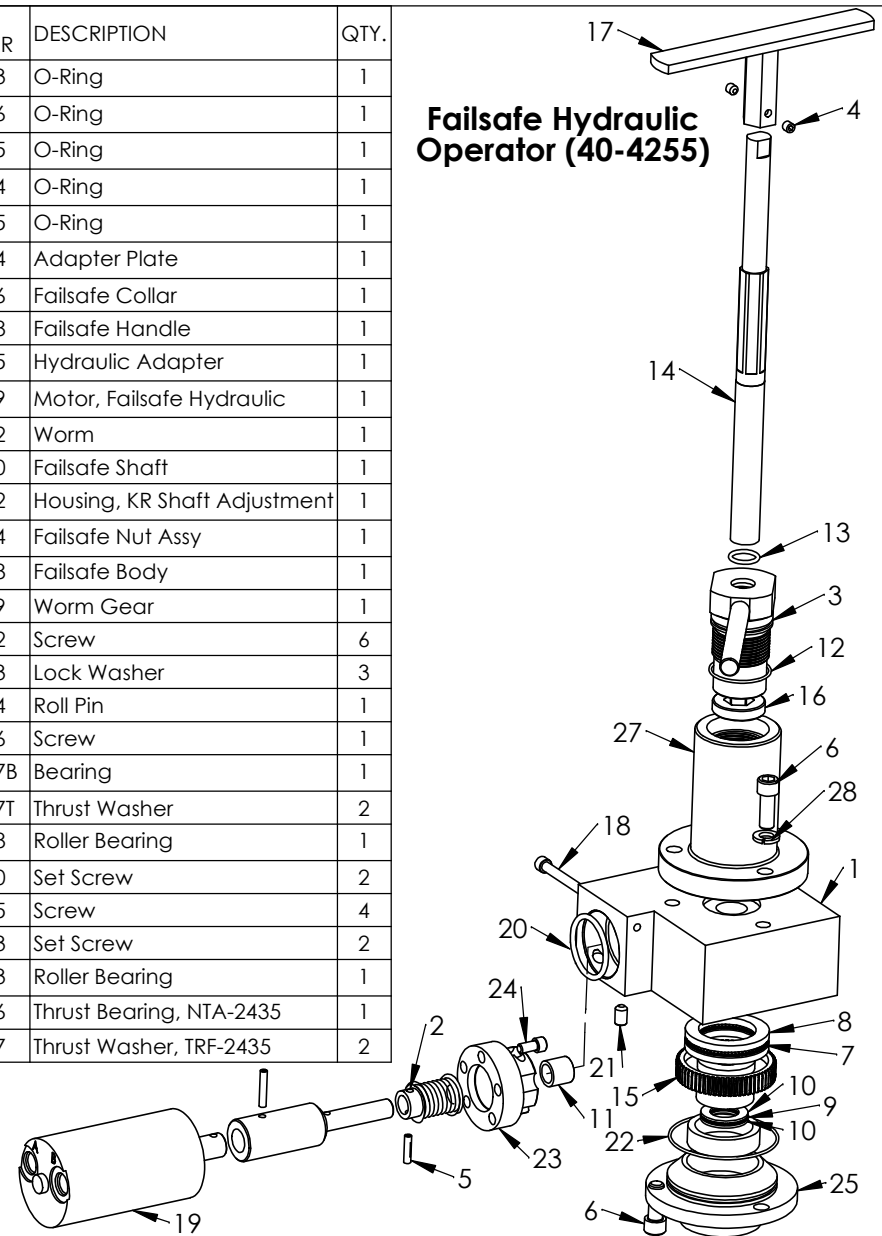

PROPRIETARY AND CONFIDENTIAL
 THE INFORMATION CONTAINED IN THIS DRAWING IS THE SOLE PROPERTY OF PacSeal. ANY REPRODUCTION IN PART OR AS A WHOLE WITHOUT THE WRITTEN PERMISSION OF PacSeal IS PROHIBITED.

TITLE Failsafe Air and Hydraulic Operators Assembly Drawing

SIZE A	REV 8
SHEET 17 OF 25	

ITEM NO.	PART NUMBER	DESCRIPTION	QTY.
1	40-2654	Plate, Upper Actuator	1
2	40-2655	Plate, Upper Spring	1
3	40-2656	Cylinder, Actuator	1
4	40-2657	Plate, Lower Spring	1
5	40-2658	Plate, Lower Actuator	1
6	40-2659	Spring, Outer	3
7	40-2660	Spring, Inner	3
8	50-0072	SHCS	8
9	50-0104	Lock Washer	4
10	50-0434	Bolt	4
11	50-0435	Rod	1

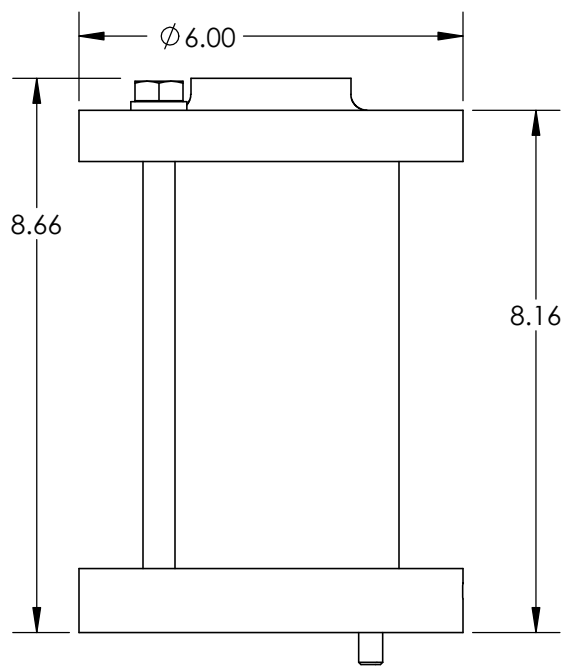
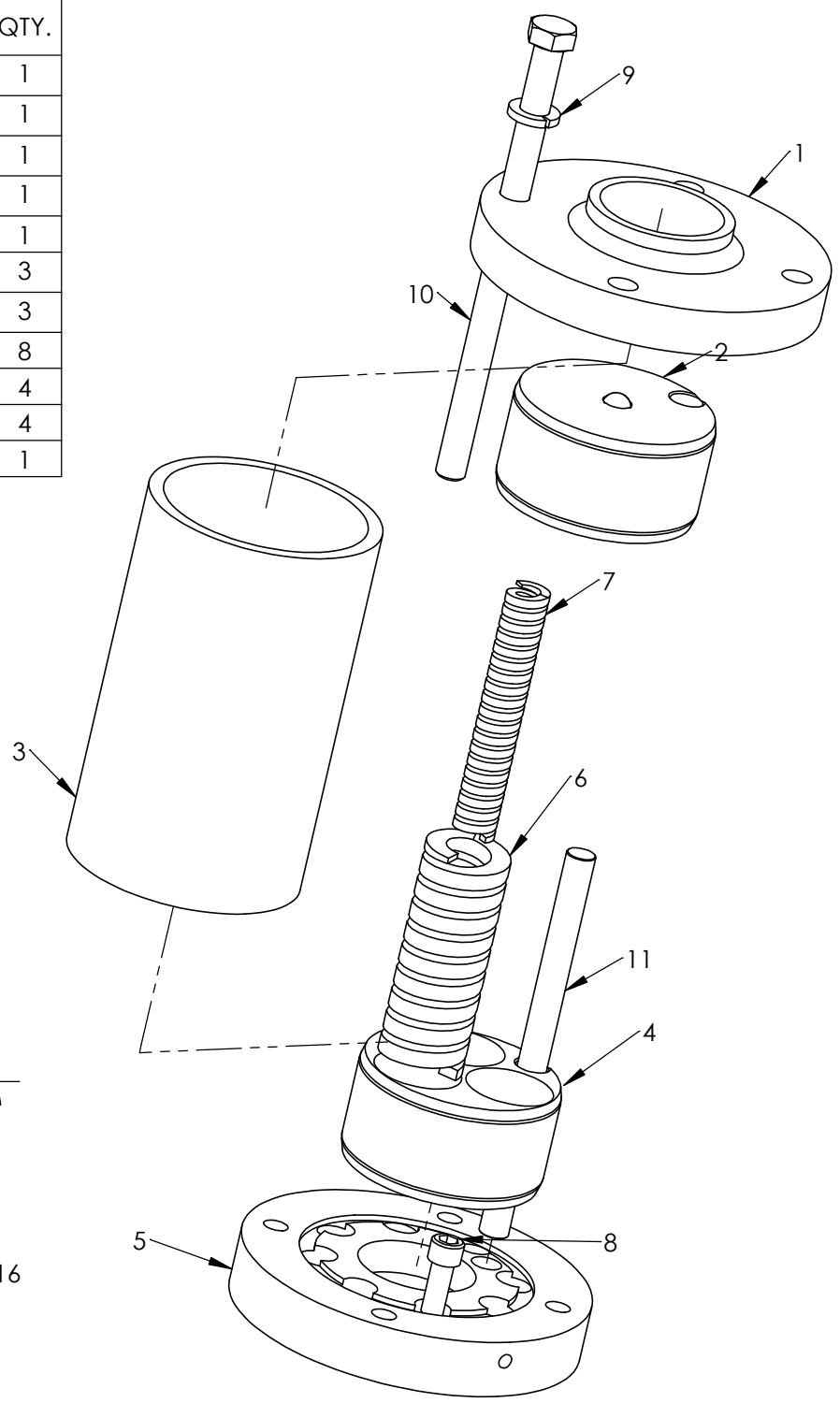

KIT PART NUMBER
40-2927



<p>PROPRIETARY AND CONFIDENTIAL THE INFORMATION CONTAINED IN THIS DRAWING IS THE SOLE PROPERTY OF PacSeal. ANY REPRODUCTION IN PART OR AS A WHOLE WITHOUT THE WRITTEN PERMISSION OF PacSeal IS PROHIBITED.</p>	<p>TITLE High Pressure Low Deadband Adjustment Head Assembly Drawing</p>	<p>SIZE A</p>	<p>REV 8</p>
		<p>SHEET 18 OF 25</p>	

ITEM NO.	PART NUMBER	DESCRIPTION	QTY.
1	40-0135	Lock Handle	1
2	40-0140	Plug, Adjustment Head	1
3	40-3237	Handle, Fail Safe HP	1
4	40-3414	Adjusting Rod	1
5	50-0482	Set Screw	2

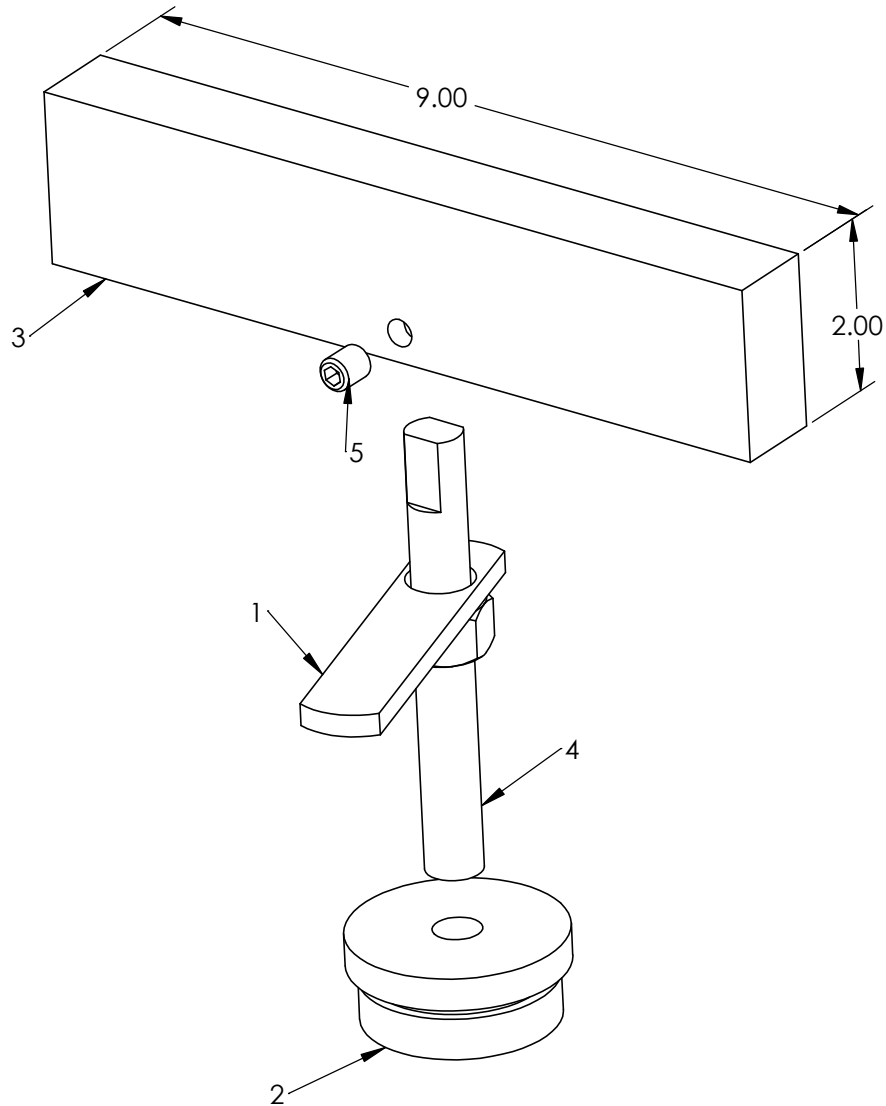

KIT PART NUMBER
40-3558



PROPRIETARY AND CONFIDENTIAL
 THE INFORMATION CONTAINED IN THIS DRAWING IS THE SOLE PROPERTY OF PacSeal. ANY REPRODUCTION IN PART OR AS A WHOLE WITHOUT THE WRITTEN PERMISSION OF PacSeal IS PROHIBITED.

TITLE
**High Pressure Output
 Manual Handle
 Assembly Drawing**

SIZE A	REV 8
SHEET 19 OF 25	

KIT PART NUMBER
40-4886

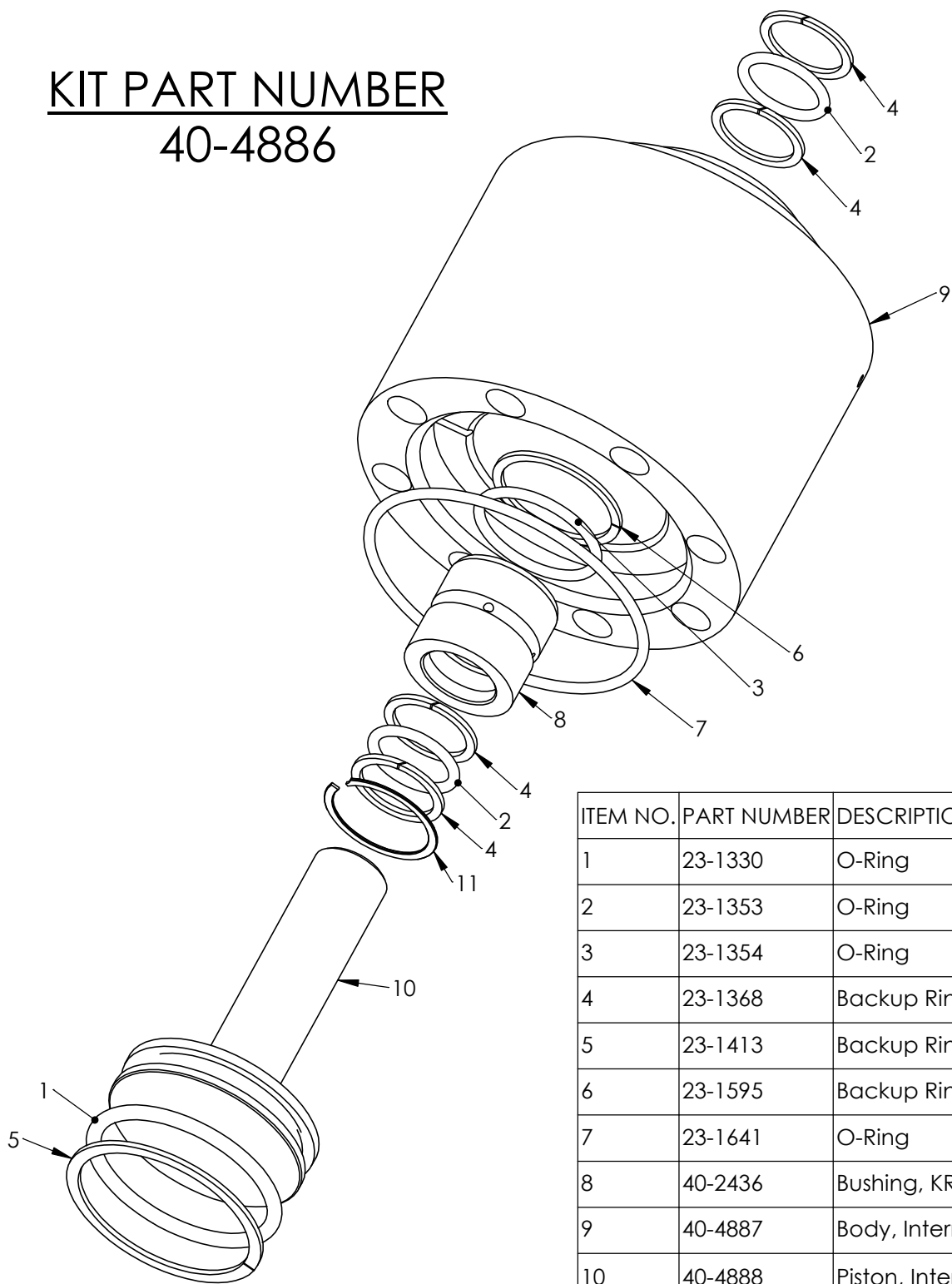

ITEM NO.	PART NUMBER	DESCRIPTION	QTY.
1	23-1330	O-Ring	1
2	23-1353	O-Ring	2
3	23-1354	O-Ring	1
4	23-1368	Backup Ring	4
5	23-1413	Backup Ring	1
6	23-1595	Backup Ring	1
7	23-1641	O-Ring	1
8	40-2436	Bushing, KR-75/140 Int Override	1
9	40-4887	Body, Internal Override	1
10	40-4888	Piston, Internal Override	1
11	50-0409	Retaining Ring	1



PROPRIETARY AND CONFIDENTIAL
THE INFORMATION CONTAINED IN THIS DRAWING IS THE SOLE PROPERTY OF PacSeal. ANY REPRODUCTION IN PART OR AS A WHOLE WITHOUT THE WRITTEN PERMISSION OF PacSeal IS PROHIBITED.

TITLE Internal Override Bypass Direct Operation Assembly Drawing

SIZE A	REV 8
SHEET 22 OF 25	

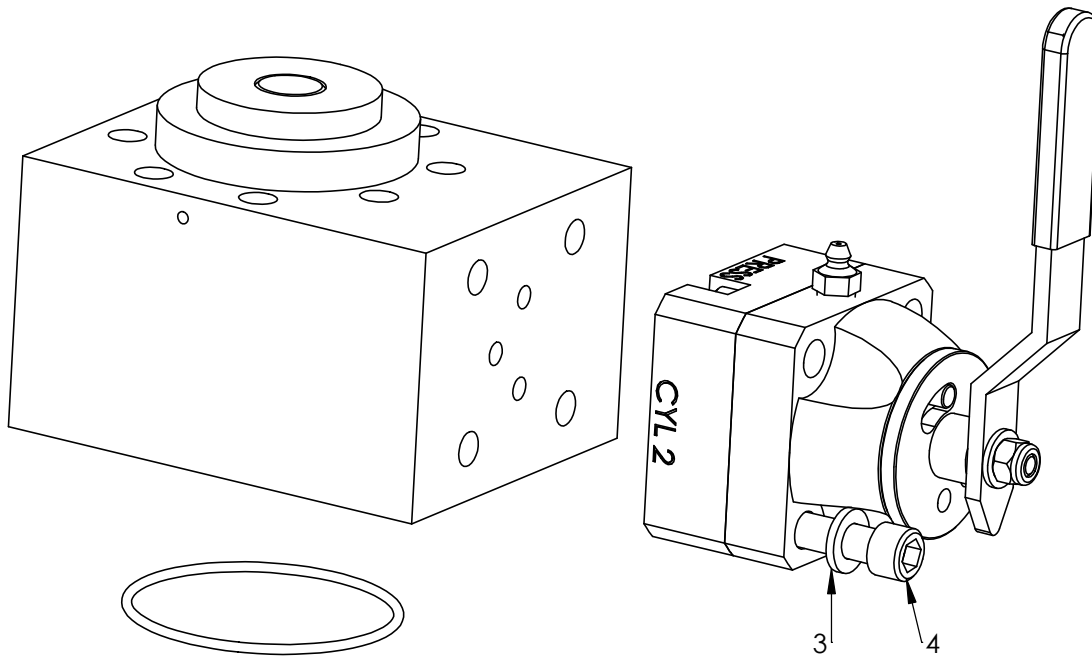

KIT PART NUMBER
40-4899

ITEM NO.	PART NUMBER	DESCRIPTION	QTY.
1	40-3301	SV-25 Open Center	1
2	40-4895	Internal Override, KR-75/140/150/200	1
3	50-0103	Lock Washer	4
4	50-0338	SHCS	4



PROPRIETARY AND CONFIDENTIAL
 THE INFORMATION CONTAINED IN THIS DRAWING IS THE SOLE
 PROPERTY OF PacSeal.
 ANY REPRODUCTION IN PART OR AS A WHOLE WITHOUT THE
 WRITTEN PERMISSION OF PacSeal IS PROHIBITED.

TITLE
**Internal Override
 Bypass w/ SV-25
 Assembly Drawing**

SIZE A	REV 8
SHEET 23 OF 25	

KIT PART NUMBER
40-4894

ITEM NO.	PART NUMBER	DESCRIPTION	QTY.
1	40-4549	SVx-25 Open Center, 2-Pos 45° CW	1
2	40-4895	Internal Override, KR-75/140/150/200	1
3	50-0103	Lock Washer	4
4	50-0549	SHCS	4

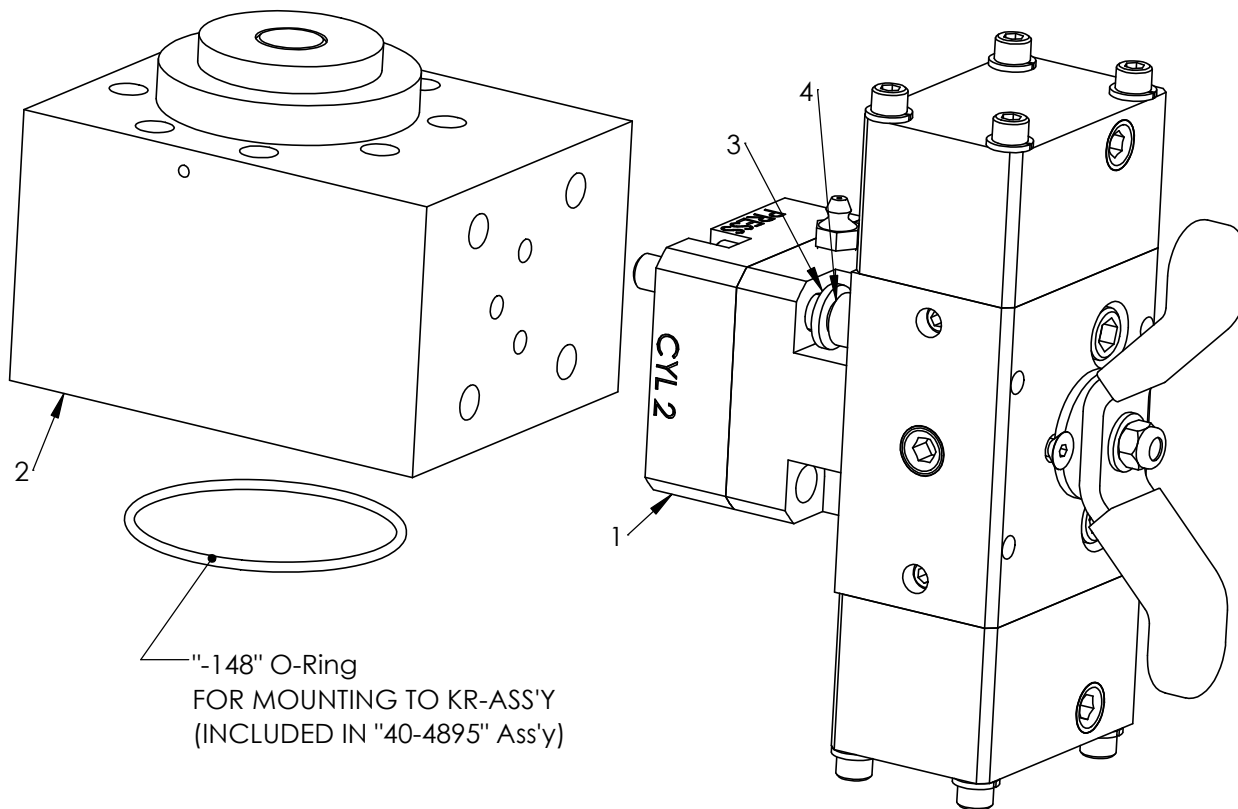

PROPRIETARY AND CONFIDENTIAL
THE INFORMATION CONTAINED IN THIS DRAWING IS THE SOLE PROPERTY OF PacSeal. ANY REPRODUCTION IN PART OR AS A WHOLE WITHOUT THE WRITTEN PERMISSION OF PacSeal IS PROHIBITED.

TITLE
**Internal Override
Bypass w/ SVx-25
Assembly Drawing**

SIZE A	REV 8
SHEET 24 OF 25	

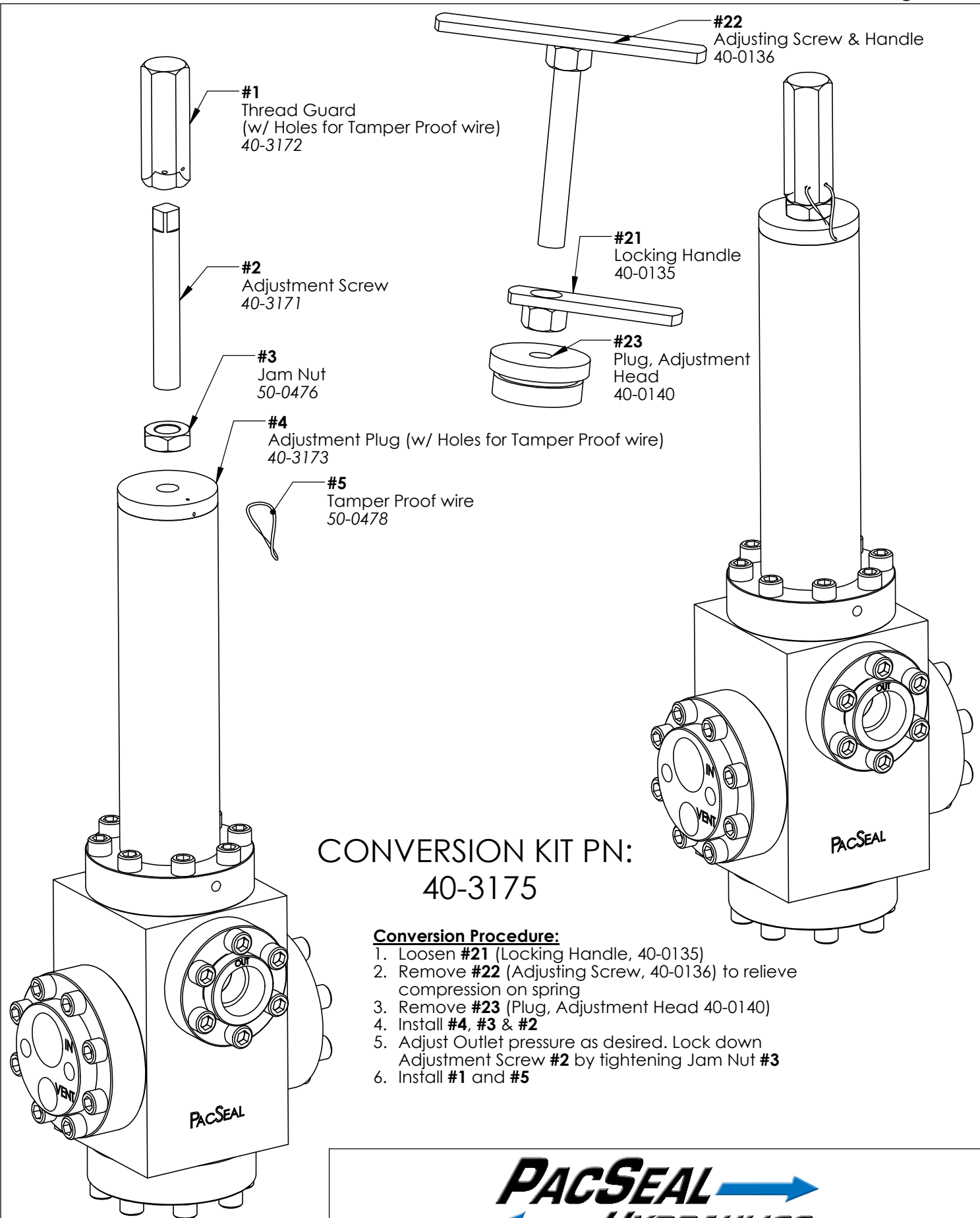

CONVERSION KIT PN:
40-3175

Conversion Procedure:

1. Loosen #21 (Locking Handle, 40-0135)
2. Remove #22 (Adjusting Screw, 40-0136) to relieve compression on spring
3. Remove #23 (Plug, Adjustment Head 40-0140)
4. Install #4, #3 & #2
5. Adjust Outlet pressure as desired. Lock down Adjustment Screw #2 by tightening Jam Nut #3
6. Install #1 and #5



PROPRIETARY AND CONFIDENTIAL
THE INFORMATION CONTAINED IN THIS DRAWING IS THE SOLE PROPERTY OF PacSeal.
ANY REPRODUCTION IN PART OR AS A WHOLE WITHOUT THE WRITTEN PERMISSION OF PacSeal IS PROHIBITED.

TITLE
Tamper Proof Conversion Kit

SIZE A	REV 8
SHEET 25 OF 25	