

**NOTES:**

- ① IO to KR Mounting Bolts (8 required, not included)
  - 50-0493: FOR MODELS "L", "R", "D" & "V"
  - 50-0327: FOR MODELS "H" & "W"
- ② OVERRIDE PRESSURE MUST BE EQUAL TO OR EXCEED INLET PRESSURE. NORMAL OPERATION MUST BE VENTED.

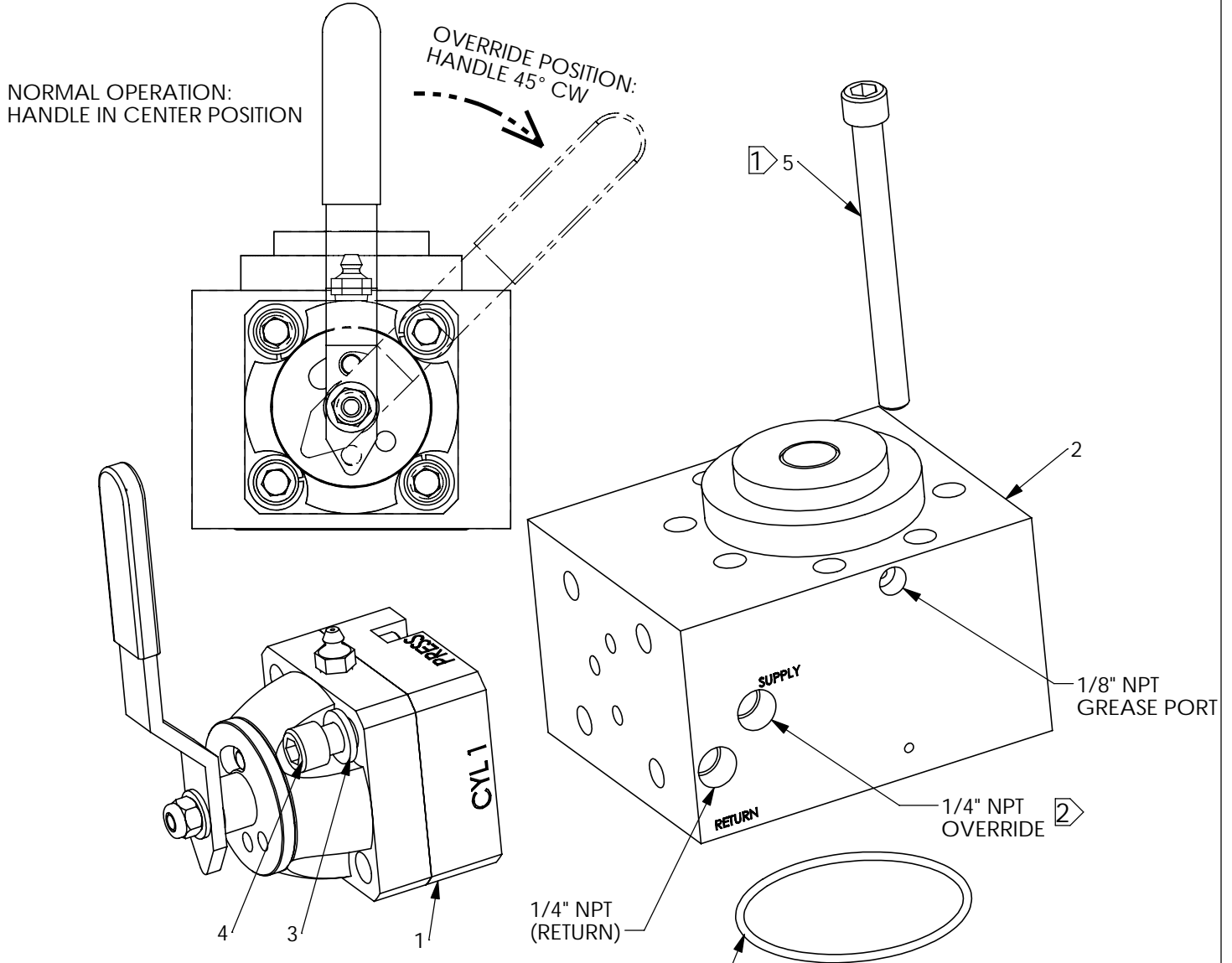

"-148" O-Ring  
FOR MOUNTING TO KR-ASS'Y  
(INCLUDED IN "40-4895" Ass'y)

ITEM NO.	PART NUMBER	DESCRIPTION	QTY.
1	40-3301	SV-25 Open Center	1
2	40-4895	Internal Override, KR-75/140/150/200	1
3	50-0103	Lock Washer	4
4	50-0338	SHCS	4
5	NOTE 1	SHCS	8

**PACSEAL HYDRAULICS INC.**

VALVES, ACCUMULATORS, CONTROLS

PROPRIETARY AND CONFIDENTIAL  
THE INFORMATION CONTAINED IN THIS DRAWING IS THE SOLE PROPERTY OF PacSeal Hydraulics. ANY REPRODUCTION IN PART OR AS A WHOLE WITHOUT THE WRITTEN PERMISSION OF PacSeal Hydraulics IS PROHIBITED.

TITLE: Internal Override, KR-75/140/150/200 w/ SV-25 OpenCenter

SIZE <b>A</b>	DWG. NO. <b>40-4899</b>	REV <b>2</b>
SCALE: 1:2	WEIGHT: 19	SHEET 1 OF 1

40-4899